

The Siemens logo is displayed in a white rectangular box. The background of the entire page features a blurred industrial setting with a Siemens device in the foreground, overlaid with a green digital grid and binary code (0s and 1s).

Flyer

Edition  
April 2017

## PROFINET in the process industry

Digitalization already starts at the field level

Switch over to green: PROFINET combines the benefits of PROFIBUS, the most widely distributed bus system worldwide, with the latest Ethernet technology. PROFINET supports easy setup of flexible communication networks and ensures integrated, reliable and secure communication throughout the plant – in real time!

Higher flexibility, efficiency and performance in industrial communication – PROFINET has proven itself for many years in the manufacturing and machine environment and is the preminent global standard in automation.

PROFINET more than meets the special requirements of the process industry regarding availability, flexibility, real-time capability and ruggedness. At the same time, the Ethernet-based technology convinces through easy handling.

### PROFINET in SIMATIC PCS 7 V9.0

Some of the fundamental PROFINET functions for the process industry have now been integrated into the SIMATIC PCS 7 process control system:

- Scalable system redundancy
- Configuration in Run (CiR)
- High-precision time synchronization for sequence of events ("SoE")

In addition, the hardware portfolio has been fundamentally expanded to take full advantages of the potential offered by PROFINET:

- SIMATIC PCS 7 CPU 410-5H V8.2
- SIMATIC ET 200SP HA
- SIMATIC CFU PA
- SCALANCE XF204-2BA DNA („Y-Switch")

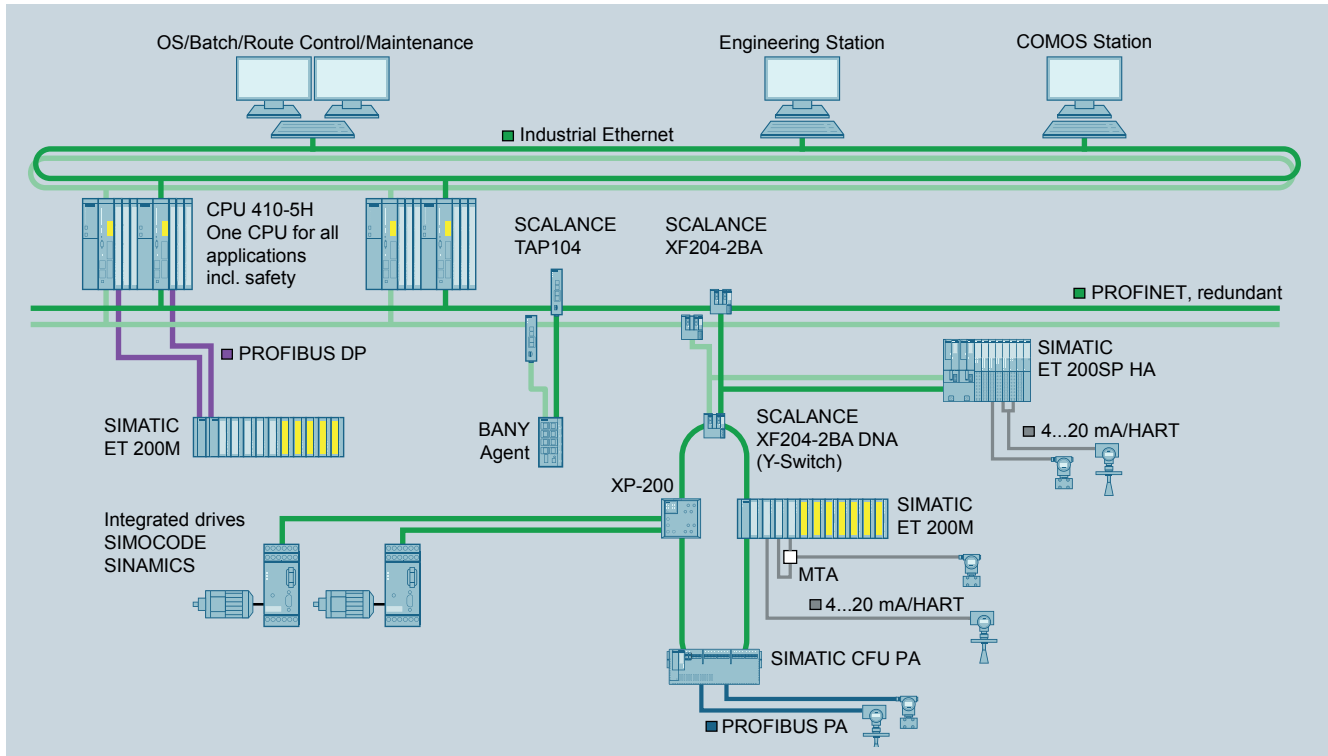

## What is PROFINET?

PROFINET completely adheres to the Ethernet standard in accordance with IEC 802.3, which makes it the reliable future-proof standard that paves the way for digitalization in the process environment.

Combine your investment protection with security in the future: On the one hand, the open Industrial Ethernet standard supports the integration of existing plant parts and technologies. This can be accomplished with the corresponding solutions and products available now, such as the IE/PB-Link PN IO to integrate PROFIBUS DP or the SIMATIC CFU PA for integration of PROFIBUS PA. On the other hand, worldwide standardization according to IEC 61158/61784 and consistent ongoing development ensure the use of PROFINET over the entire life cycle of the plant and beyond. Even wireless communication technologies such as WLAN according to IEEE 802.11 or mobile communications can be reliably integrated.

Wired communication will also become easier and more cost-effective with PROFINET: The motto "One cable for all purposes" supports parallel operation of profiles such as PROFI-safe, PROFIdrive and other TCP/IP protocols without impacting basic plant communication.

You can also gain more convenience: PROFINET diagnostics are available by default; they simplify installation and offer support when servicing your plant. Network problems and device conflicts are reliably detected and can be quickly remedied. This also creates the basis for predictive maintenance. These benefits pay off during the entire plant life cycle.

## Tailored to meet your requirements

PROFINET allows you to freely scale the availability of your plant based on your requirements. In addition to media redundancy (MRP), two forms of system redundancy are available:

- Single system redundancy (S2)
- Redundant system redundancy (R1)

The new hardware components enable you to make changes during operation using the PROFINET function "Configuration in Run".

Flexible architectures have the potential for significant savings in wiring. A fact confirmed by reference projects. In one case, wiring over a length of 27 km (with PROFIBUS DP) could be reduced to 9 km by using PROFINET. Flexible architectures also support easy plant expansion without the need for keeping reserves.

The new hardware components use the BusAdapter technology, which supports simple and flexible connection to the PROFINET network either with copper cables (RJ45 or FastConnect) or fiber-optic cables.

## Functionalities

Digitalization in the process industry significantly increases the amount of data (Big Data), requires continuous communication all the way to the field and needs flexible and secure communication networks.

PROFINET is the answer:

- **The best of both worlds**
  - Compatible with PROFIBUS
  - Integrated device/network diagnostics
  - High data rates for more data, digital and in real time
  - Fail-safe communication is possible without special network components
- **Standardization**
  - Based on Ethernet standard according to IEC 802.3
  - Worldwide leading open field bus standard
  - Supports IT services, e.g. TCP/IP
- **Straightforward handling**
  - Support during planning, operation and commissioning through automatic addressing and name assignment
  - Easy device replacement without additional tools through automatic neighborhood detection
  - Clear and simple installation guidelines

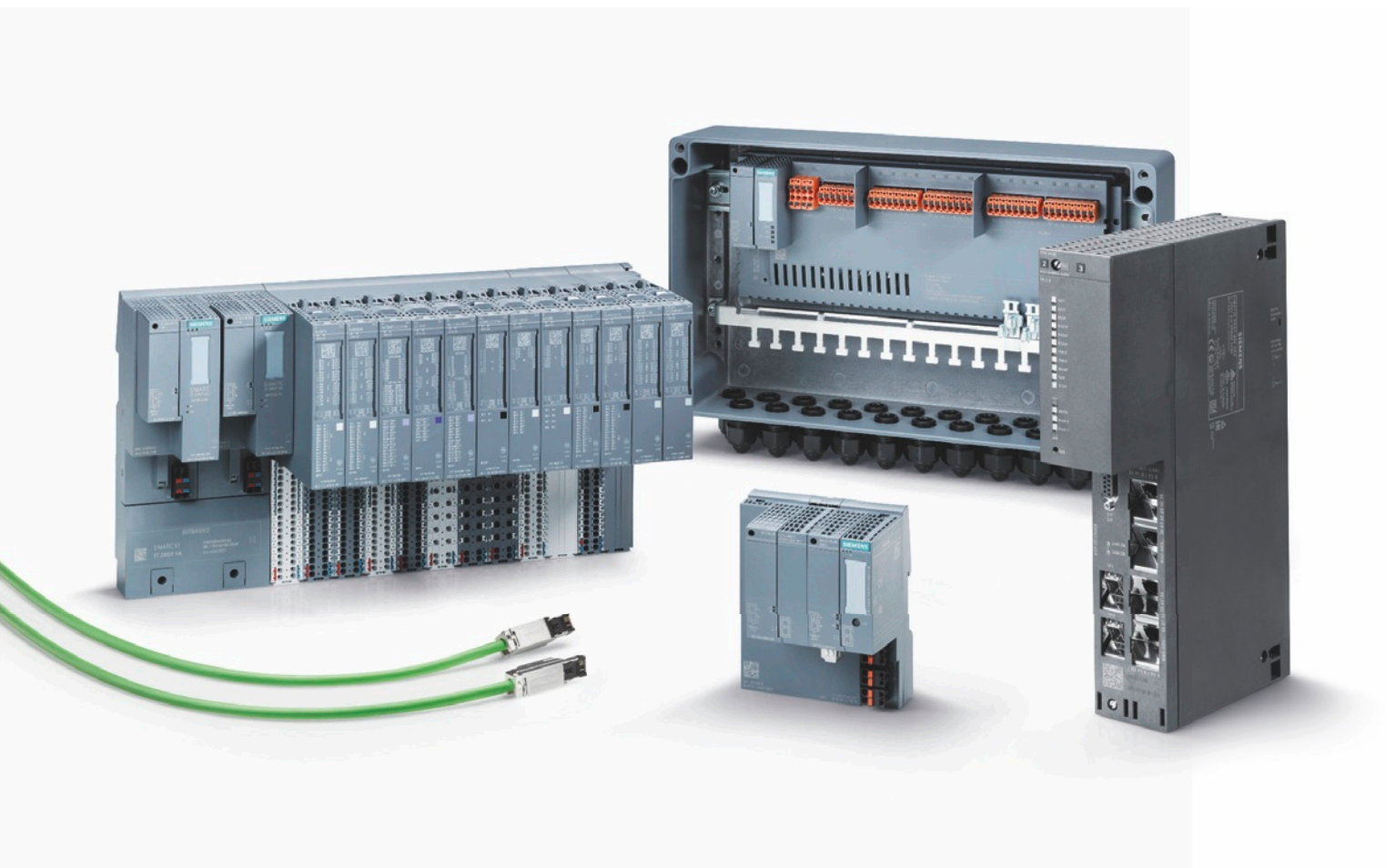



## Your benefits

- **Ethernet at the field level**
  - Integrated vertical and horizontal communication
  - Transmission of large amounts of data in real time
- **Maximum availability upon request**
  - Changes in Runtime
  - Free scalable redundancy allows for high cost reductions and optimally customized solutions
- **More flexibility**
  - One shared plant network ensures free assignment of the devices to the controllers and makes it easy to expand the plant
  - Topologies are based on requirement and plant specification, which results in savings of 60% and more in cabling!
  - "One cable for all purposes" means better cost efficiency
- **User friendly**
  - Simple device integration and fast device replacement during operation
  - Installation wizards and integrated device/network diagnostics
  - Implementation of a safe communication layer according to IEC 61784-3-3 (PROFIsafe)
- **Investment protection**
  - Integration of existing structures and technologies
  - Gradual transition from PROFIBUS DP to PROFINET!

Siemens AG  
Process Industries and Drives  
Automation and Engineering  
76181 Karlsruhe  
Germany

Subject to change without prior notice  
E86060-A4678-A371-A1-7600  
FL 0417 .5 GUT 2 En  
Printed in Germany  
© Siemens AG 2017

The information provided in this flyer contains descriptions or characteristics of performance which in case of actual use do not always apply as described or which may change as a result of further development of the products. An obligation to provide the respective characteristics shall only exist if expressly agreed in the terms of contract. Availability and technical specifications are subject to change without prior notice.

All product designations may be trademarks or product names of Siemens AG or supplier companies whose use by third parties for their own purposes could violate the rights of the owners.