



**SIEMENS**



# SCE Training Curriculum

Siemens Automation Cooperates with Education (SCE) | 09/2015

**PA Module P01-01**  
**SIMATIC PCS 7 – Process Description**

Cooperates  
with Education

Automation

**SIEMENS**

## Matching SCE Trainer Packages for this curriculum

- **SIMATIC PCS 7 Software block of 3 packages**  
Order No. 6ES7650-0XX18-0YS5
- **SIMATIC PCS 7 Software block of 6 packages**  
Order No. 6ES7650-0XX18-2YS5
- **SIMATIC PCS 7 Software Upgrade block of 3 packages**  
Order No. 6ES7650-0XX18-0YE5 (V8.0 → V8.1) or 6ES7650-0XX08-0YE5 (V7.1 → V8.0)
- **SIMATIC PCS 7 Hardware Set including RTX Box**  
Order No. 6ES7654-0UE13-0XS0

Please note that these trainer packages may be replaced with subsequent packages.  
An overview of the available SCE packages is provided at: [siemens.com/sce/tp](https://www.siemens.com/sce/tp)

## Continuing education

For regional Siemens SCE continuing education, contact your regional SCE contact partner  
[siemens.com/sce/contact](https://www.siemens.com/sce/contact)

## Additional information relating to SIMATIC PCS 7 and SIMIT

In particular, Getting Started, videos, tutorials, manuals and programming guide.  
[siemens.com/sce/pcs7](https://www.siemens.com/sce/pcs7)

## Additional information relating to SCE

[siemens.com/sce](https://www.siemens.com/sce)

## Note on Usage

The training curriculum for the integrated automation solution Totally Integrated Automation (TIA) was prepared for the program "Siemens Automation Cooperates with Education (SCE)" specifically for training purposes at public educational and R&D facilities. Siemens AG is not liable for the contents.

This document may only be used for initial training on Siemens products/systems. This means it may be copied entirely or partially and handed to trainees for use within the scope of their training. Passing on or copying this document and communicating its contents is permitted within public training and continuing education facilities for training purposes.

Exceptions require written permission by Siemens AG. Contact person: Roland Scheuerer  
[roland.scheuerer@siemens.com](mailto:roland.scheuerer@siemens.com).

Violators are subject to damages. All rights including translation rights are reserved, particularly in the event a patent is granted or a utility model or design is registered.

Usage for industrial customer courses is explicitly not permitted. We do not agree to the commercial utilization of these documents.

We would like to thank the Technical University Dresden, particularly Prof. Dr. Leon Urbas and Annett Krause, MS, as well as the Michael Dziallas Engineering Corporation and those who provided support in preparing this SCE training document.

# PROCESS DESCRIPTION

## CLASSIFICATION OF PROCESS ENGINEERING PLANTS

To effectively automate process engineering plants, structuring the plant as well as describing its intended utilization is necessary. It is helpful in this case to subdivide the plant into classes of process engineering plants that are similar regarding the requirements for automation engineering. According to [1], the number of fundamentally different products and the physical structure of the plant can be used for classification.

If the same product is always manufactured in a plant, it is called a **single product process cell**. If the environmental conditions change or the composition of the educts fluctuates, only the parameters of the process sequence or the settings are to be varied in these plants to always get the same product. In a **multi-product process cell**, on the other hand, different products are manufactured either according to different processes or according to the same process but with clearly different parameters.

From the view of automation, the **single train process cell** represents the simplest physical structure of a plant. The intermediate steps of the product traverse the units in a fixed sequence. A **multi train process cell** consists of several parallel single lines; however, no product transfer is intended between them. Only material quantities and finished product inventories are used jointly by the single lines. A **multi train-multi path process cell** also consists of single lines, but in contrast to the simple multi train plant, product exchange between lines is possible. Here, the paths can either be fixed, dynamic with a fixed connection, or dynamic with a flexible connection.

## PROCESS CELL DESCRIPTION

In this instruction module, the laboratory plant shown in the adjacent Figure 1 is being automated.

The core of the plant consists of 2 reactors that are loaded with different educts. In the reactors, different products can be made at the same time. For that reason, the plant can be classified as **multi-product plant** and **multi train-multi path plant**. It consists of several units that are permanently connected to each other. Depending on the production process, it is possible to wire the lines between the units dynamically. This requires complex automation. In the following chapters of this training module we will learn, however, that by taking into account a few simple principles and rules, the complicated automation system can be assembled quite effectively and efficiently by combining existing blocks of the **PCS 7** process control system.



Figure 1: Multi product and multi train-multi path process cell at TU Dresden as playground for modern process control engineering

The first unit provides the educts for the reactors. It consists of three educt containers. Their instrumentation is identical. To ascertain whether the container is empty or full, the level is monitored by two sensors. With a valve at the outlet and a pump, the educt can be dosed for the second unit. The educt is refilled by means of a valve at the inlet.

The second unit consists of two reactors that have the same dimensions as the educt containers but are equipped with other automation resources. Each reactor is provided with an agitator and a heater. The level is continuously measured by an ultrasound sensor, and the temperature with a PT100 element. The educts are drained into the reactor by means of the three valves at the inlet. With a pump at the outlet, the reaction product can either be transferred to the other reactor, drained into the product tank of the third unit or the rinsing water can be returned to the rinse water container. An additional valve at the inlet allows for the reactor being cleaned with rinsing water from the fourth unit.

The third unit contains the finished products and consists of two containers with two sensors that display the minimum and the maximum level. While the reactors can be loaded by all educt containers, the product containers are assigned exactly to one reactor. With a valve at the inlet of the product container, the path from the reactor to the product container is released. A valve each at the outlet of the product containers serves to remove the finished product from the plant.

The fourth unit consists of a rinse water container. It also is equipped with two sensors to indicate the minimum and maximum level. With a valve and a pump at the outlet, the rinsing water can be transported to the reactors of the second unit, and by means of the valves at the inlet back again from the reactors.

## PIPING AND INSTRUMENTATION DIAGRAM

Although a textual description of a plant explains the essential relationships, it is not very suitable to communicate the joint tasks of process engineering, electro-technical engineering and automation engineering, because a textual description is prone to misunderstandings even where small plants are concerned, but above all in the case of large plants with hundreds of devices and several tens of thousands of measuring points.

In the course of time, the *Piping & Instrumentation Diagram* (P&ID) has developed into a central planning tool for that reason. The P&ID documents the structure and function of the process system for process as well as automation engineering. Figure 2 shows the P&ID of the experimentation plant that is to be automated in this instruction module.

Containers, valves and pumps as well as functional requirements of process control engineering are represented by standardized symbols in the P&ID. The piping between the elements is indicated as solid lines, the flow of information as dashed lines. For the sake of clarity, all units are shown in a P&ID in Figure 2.

A container or a process control function is associated with a certain unit by means of an identification system. This identification system provides clarity for persons as well as the computer. As long as people work closely together, they can easily distinguish between educt container B001 and the product tank B001 based on the context. This distinction becomes more difficult when communication takes place across several departments, when employees are processing many projects simultaneously and when computers are involved. The complete designation for the first educt container B001 is therefore =**SCE.A1.T1-B001**. This means tank **B001** in factory **SCE**, plant **A1**, unit **T1** can be clearly distinguished from a similar plant or unit.

## SAFETY INTERLOCK AND PROTECTION FUNCTIONS

The P&ID is not sufficient to specify all requirements for process control engineering. To ensure safe plant operation, the controller has to do the following: monitor process intervention and, if needed, suppress user input, switch actuators on or off, mutually lock functions and/or take the plant to a safe state. For the plant described above that is equipped with meters according to Figure 2, the following monitoring and locking functions are required and implemented step by step with **PCS 7** within the instruction modules:

- Actuators must be switched only if the main switch of the plant is switched on and the Emergency Off switch is enabled.
- Containers must not overflow; this means there is either a sensor that signals the maximum level, or the maximum level (here: 1000ml) is known numerically and is evaluated by means of the measured level.
- Pumps must not take in air; this means there is either a sensor that signals the minimum level, or the minimum level (here: 50ml) is known numerically and is evaluated by means of the measured level.
- Pumps must not attempt to take in liquid when a valve is closed or pump liquid against a closed valve.
- The temperature in the two reactors must not exceed 60°C.
- The heaters of the two reactors must only be operated if they are covered with liquid (here: a minimum of 200ml in the reactor).
- The agitators of the two reactors should be operated only if they are in contact with liquid (here: a minimum of 300ml in the reactor).

## RECIPE

According to [1], a recipe is a specification for manufacturing a product according to a procedure. It describes what is needed to carry out a procedure. For the plant described above, the following recipe applies which is implemented within this instruction module with **PCS 7**:

1. First, 350ml are to be drained from educt tank =SCE.A1.T1-B003 into the reactor =SCE.A1.T2-R001 and, at the same time, 200ml are to be drained from educt tank =SCE.A1.T1-B002 into the reactor =SCE.A1.T2-R002.
2. When reactor =SCE.A1.T2-R001 is filled, the liquid is to be heated to 25°C with the agitator switched on.
3. When reactor =SCE.A1.T2-R002 is filled, 150ml of educt A from educt tank =SCE.A1.T1-B001 is to be added to the reactor =SCE.A1.T2-R002. When this is completed, the agitator of reactor =SCE.A1.T2-R002 is to be switched on 10s later.
4. When the temperature of the liquid in reactor =SCE.A1.T2-R001 has reached 25°C, the mixture is to be pumped from reactor =SCE.A1.T2-R002 to reactor =SCE.A1.T2-R001.
5. The mixture in reactor =SCE.A1.T2-R001 is now to be heated to 28°C and then drained into product tank =SCE.A1.T3-B001.

## LITERATURE

- [1] DIN EN 61512-1 (Status 2000-01): Batch Oriented Operation.

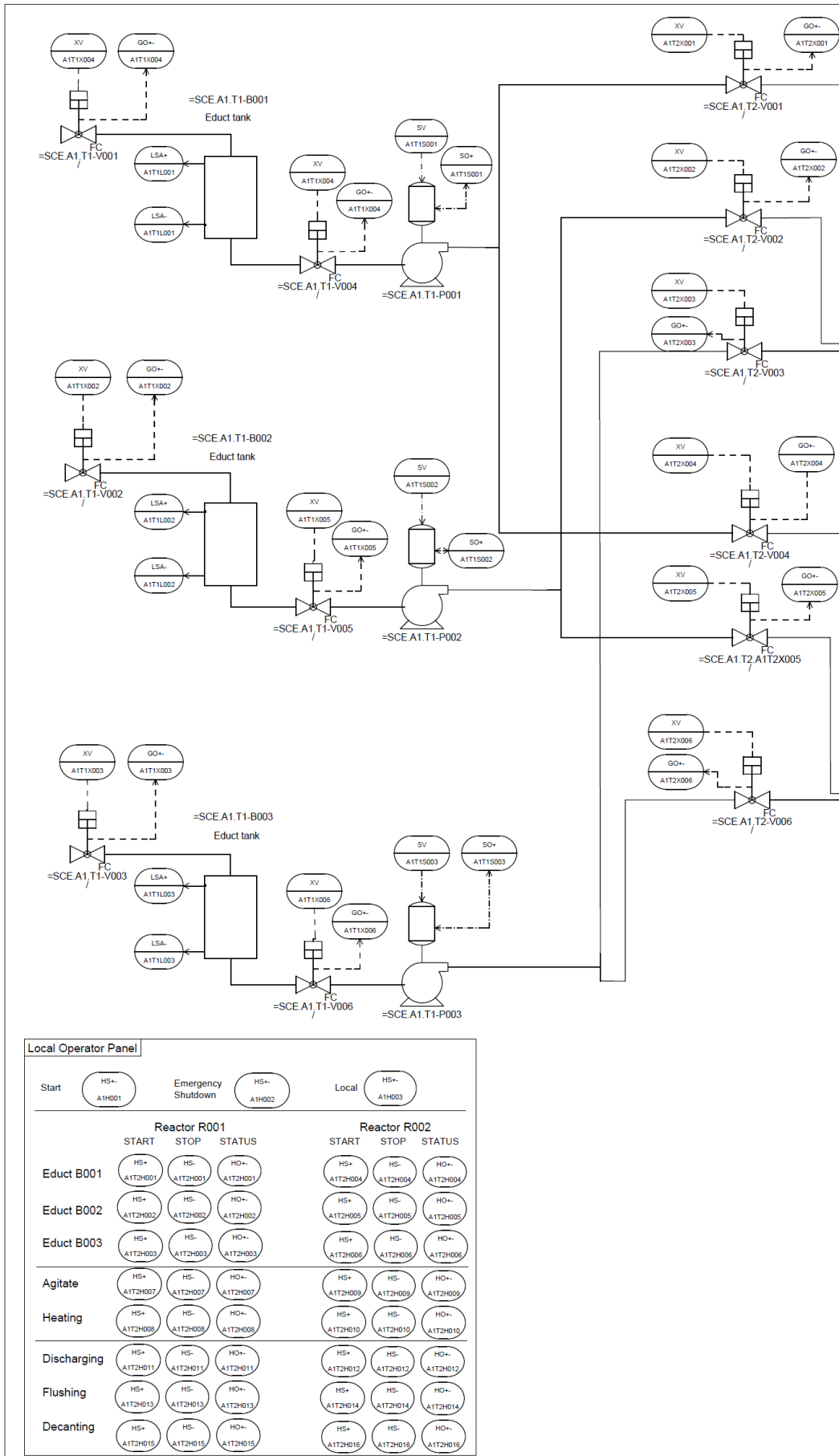

Figure 2: Configured process cell (Part 1)

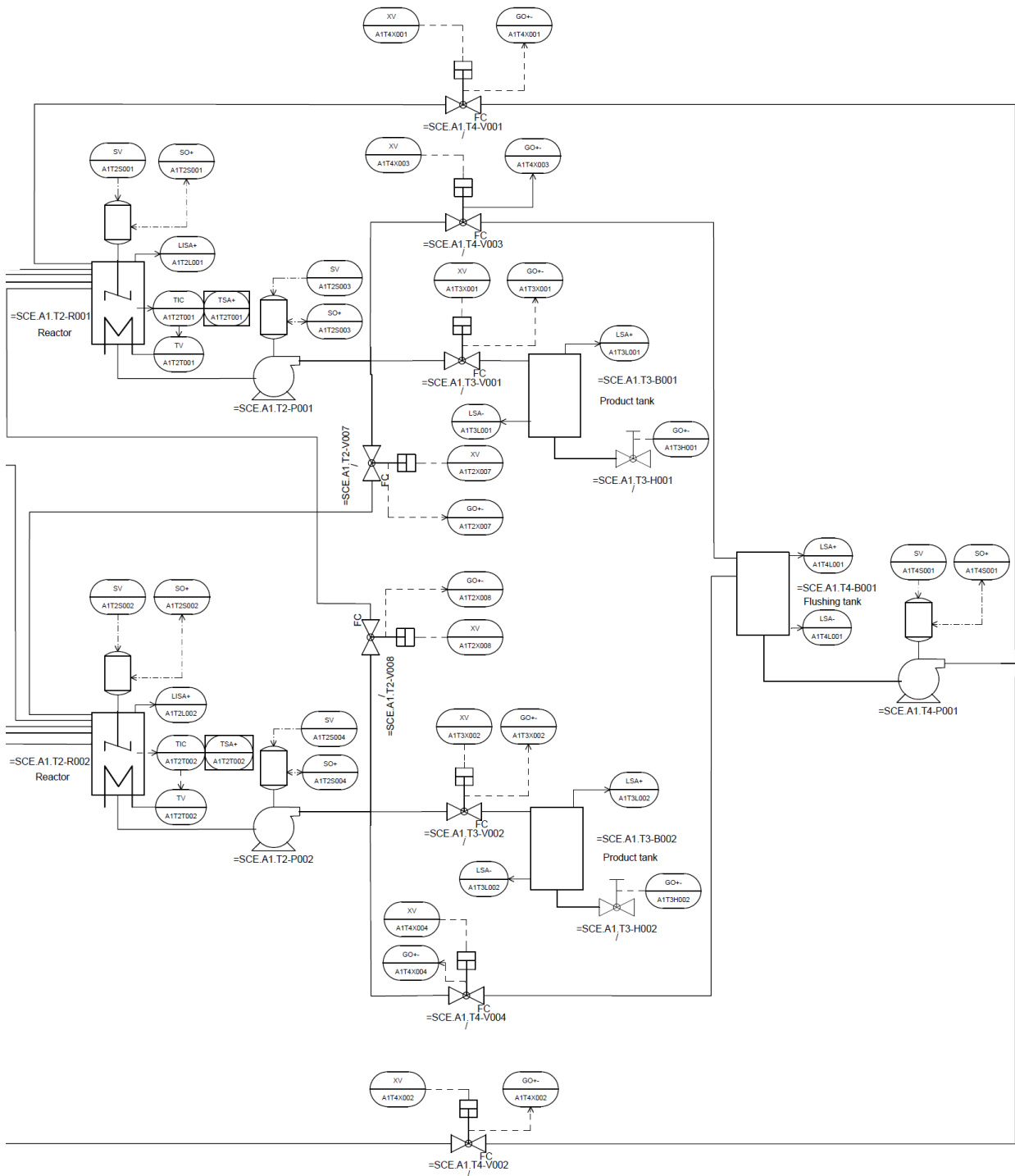

Figure 2: Configured process cell (Part 2)