

# SITRANS F flowmeters

## SITRANS F C

### MASS 2100 DI 3 to DI 40

#### Overview

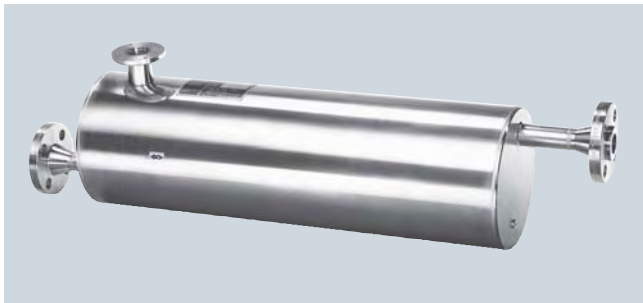

MASS 2100 DI 3 to DI 40 is suitable for accurate mass flow measurement of a variety of liquids and gases.

The sensor offers superior performance in terms of flow accuracy, turn-down range and density accuracy. The ease of installation through a "plug & play" mechanical and electrical interface ensures optimum performance and operation.

The sensor delivers true multi parameter measurements i.e.: Mass flow, volume flow, density, temperature and fraction.

#### Benefits

- High accuracy better than 0.1% of mass flow rate
- Large dynamic turn down range better than 500:1
- Densitometer performance available through a density accuracy better than 0.0005 g/cm<sup>3</sup> with a repeatability better than 0.0001 g/cm<sup>3</sup>
- Single continuous tube design, with no internal welds, reductions or flow splitters offers optimal hygiene, safety and CIP clean-ability for food & beverage and pharmaceutical applications
- Markets biggest wall thickness, ensuring optimal lifetime and corrosion resistance and high pressure durability
- Full bore design provides lower pressure loss due to same internal diameter throughout the entire sensor.
- Balanced pipe design with little mechanical energy-loss, ensures optimal performance and stability under non ideal and unstable process conditions (pressure, temperature, density-changes etc.)
- 4-wire Pt1000 temperature measurement ensures optimum accuracy on mass flow, density and fraction flow
- Multi-plug electrical connector & SENSORPROM enables true plug&play. Installation and commissioning in less than 10 min.
- Intrinsically safe Ex-design ia IIC as standard, making service in hazardous area possible without having to demount the sensor if a compact Ex d transmitter needs service
- Sensor pipe available in high quality AISI 316L stainless steel 1.4435 or Hastelloy C 22 2.4602 offering optimum corrosion resistance
- Centre-block design decouples process noise from the environment such as vibrations, pulsations, pressure shocks etc. making installation flexible and versatile
- Rugged and space saving sensor design in stainless steel matching all environments
- High pressure program as standard
- The sensor calibration factor is also valid for gas measurement
- Uniform sensor interface matching all transmitter versions at the same time whether it is compact IP67/NEMA 4X, compact Ex d or remote installation, one sensor fits all

#### Application

Coriolis mass flowmeters are suitable for measuring all liquids and gases. The measurement is independent of changes in process conditions/parameters such as temperature, density, pressure, viscosity, conductivity and flow profile.

Due to this versatility the meter is easy to install and the coriolis flowmeter is recognized for its high accuracy in a wide turn down range which is a paramount in many applications.

**The main applications of the coriolis flowmeter can be found in all industries, such as:**

<b>Chemical &amp; pharma</b>	Detergents, bulk chemicals, pharmaceuticals, acids, alkalis
<b>Food &amp; beverage</b>	Dairy products, beer, wine, soft-drinks, plato/brix, fruit juices and pulps, bottling, CO <sub>2</sub> dosing, CIP-liquids
<b>Automotive</b>	Fuel injection nozzle & pump testing, filling of AC units, engine consumption, paint robots
<b>Oil &amp; gas</b>	Filling of gas bottles, furnace control, CNG-dispensers, test separators, LPG
<b>Water &amp; waste water</b>	Dosing of chemicals for water treatment

The wide variety of combinations and versions from the modular system means that ideal adaptation is possible to each measuring task.

#### Design

The MASS 2100 sensor consists of a single bent tube in a double bent pipe configuration, welded directly to the process connectors at each end.

The centre-block is brazed onto the sensor pipes from the outside acting as a mechanical low pass filter.

The sensor is available in 2 material configurations, AISI 316L or Hastelloy C 22 with a wide variety of process connections.

The enclosure is made in stainless steel AISI 316L 1.4404 with a grade of encapsulation of IP66/NEMA 4.

The sensor is as standard EEx ia approved, intrinsically safe

The sensor can be installed in horizontal or vertical position. In horizontal position the sensor is self draining.

**Heating Jacket:** All the sensors MASS 2100, Di 3 to Di 40, can optionally be equipped with a heating coil to avoid solidification of sensitive fluids during down time or period between discontinuing processes. This feature gives the user an alternative to the costly electrical heating normally used, as gives the freedom to choose either hot water, superheated steam or hot oil, to maintain a constant temperature inside the sensor.

# SITRANS F flowmeters

## SITRANS F C

**MASS 2100 DI 3 to DI 40**

### Function

The measuring principle is based on coriolis law of movement, see "System information SITRANS F C coriolis mass flowmeters".

### Integration

The sensor can be connected to all MASS 6000 transmitters for compact as well as remote installation.

All sensors are delivered with a SENSORPROM containing all information about calibration data, identity and factory pre-programming of transmitter settings.

#### Installation guidelines MASS 2100 DI 3 ... DI 40 (1/8" ... 1 1/2")

##### Installation of sensor

	Liquid	Gas
Horizontal		
Vertical		

If the liquid is volatile or contains solid particles, vertical mounting is not recommended.

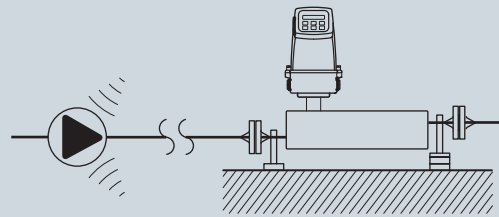

#### Vibration

Always locate the flowmeter as far away as possible from components that generate mechanical vibration in the piping.

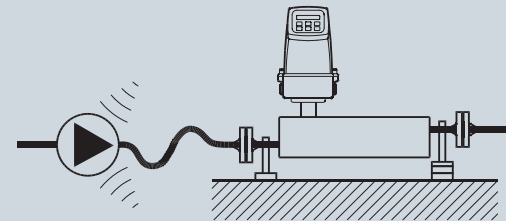

#### Cross talk

Cross talk between sensors mounted close to each other may disturb the measurement. To avoid cross talk never mount more than one meter on each frame and mount flexible hose connections between the sensors as shown.

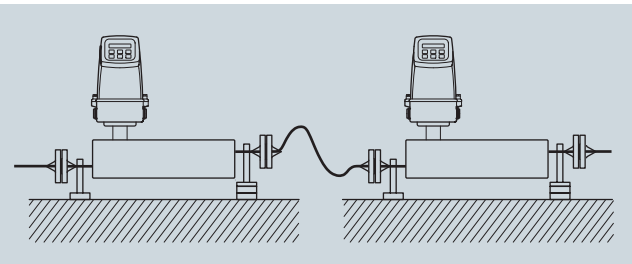

#### Zero point adjustment

To facilitate zero point adjustment a shut-off valve should always be mounted in connection with the sensor as a proper zero point setting is essential for a good accuracy.

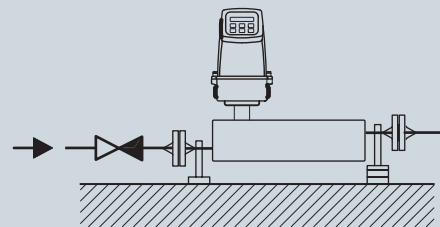

# SITRANS F flowmeters

## SITRANS F C

### MASS 2100 DI 3 to DI 40

#### Technical specifications

Versions	mm (inch)	DI 3 (1/8)	DI 6 (1/4)	DI 15 (5/8)	DI 25 (1)	DI 40 (1½)
<b>Inside pipe diameter</b> (sensor consists of one continuous pipe)	mm (inch)	3.0 (0.12)	6.0 (0.24)	14.0 (0.55)	29.7 (1.17)	43.1 (1.70)
<b>Pipe wall thickness</b>	mm (inch)	0.5 (0.02)	1.0 (0.04)	1.0 (0.04)	2.0 (0.08)	2.6 (0.10)
<b>Mass flow measuring range</b>	kg/h (lb/h)	0 ... 250 (0 ... 550)	0 ... 1.000 (0 ... 2.200)	0 ... 5.600 (0 ... 12.345)	0 ... 25.000 (0 ... 55.100)	0 ... 52.000 (0 ... 114.600)
<b>Density</b>	g/cm <sup>3</sup> (lb/inch <sup>3</sup> )	0 ... 2.9 (0 ... 0.10)				
<b>Fraction e.g.</b>	°Brix	0 ... 100				
<b>Temperature</b>						
Standard	°C (°F)	-50 ... +180 °C (-58 ... +356 °F)				
<b>Liquid pressure measuring pipe<sup>1)</sup></b>						
Stainless steel	bar (psi)	230 (3336)	265 (3844)	130 (1885)	110 (1595)	105 (1523)
Hastelloy C-22	bar (psi)	350 (5076)	410 (5946)	200 (2900)	185 (2683)	not available
<b>Materials</b>						
Measuring pipe, flange and thread connection		1.4435 (AISI 316L) (Stainless steel)				
		2.4602 (Hastelloy C-22)				not available
<b>Enclosure and enclosure material</b>		IP65 (NEMA 4) and 1.4404 (AISI 316L) (Stainless steel), <b>housing is not rated for pressure containment</b>				
<b>Process connections<sup>2)</sup></b>						
<b>Flange</b>						
EN 1092-1, PN 40			DN 10	DN 15	DN 25	DN 40
ANSI B16.5, Class 150			½"	½"	1"	1½"
ANSI B16.5, Class 600 (Class 300)			½"	½"	1"	1½"
<b>Dairy screwed connection (PN 16/25/40)<sup>3)</sup></b>						
DIN 11851			DN 10	DN 15	DN 32	DN 40
ISO 2853/BS 4825 part 4 (SS3351)			25 mm	25 mm	38 mm	51 mm
<b>Dairy clamp connection (PN 16)<sup>3)</sup></b>						
ISO 2852/BS 4825 part 3 (SMS3016)			25 mm	25 mm	38 mm	51 mm
<b>Thread</b>						
ISO 228/1, PN 100		G¼" female	G¼" male	G½" male	G1" male	G2" male
ANSI/ASME B1.20.1, PN 100		¼" NPT female	¼" NPT male	½" NPT male	1" NPT male	2" NPT male
<b>Cable connection</b>		Multiple plug connection to sensor 5 x 2 x 0.35 mm <sup>2</sup> twisted and screened in pairs, ext. Ø 12 mm				
<b>Ex-version</b>		EEx ia IIC T3-T6, DEMKO 03 ATEX 135252X				
<b>Weight approx.</b>	kg (lb)	4 (8.8)	8 (17.6)	12 (26.5)	48 (105.8)	70 (154.5)

<sup>1)</sup> Max. at 20 °C (68 °F), DIN 2413, DIN 17457

<sup>2)</sup> Other connections to order, see "Selection and Ordering data"

<sup>3)</sup> Material, 1.4401 or corresponding

For accuracy specification see "System information SITRANS F C".

# SITRANS F flowmeters SITRANS F C

MASS 2100 DI 3 to DI 40

4

Pressure drop

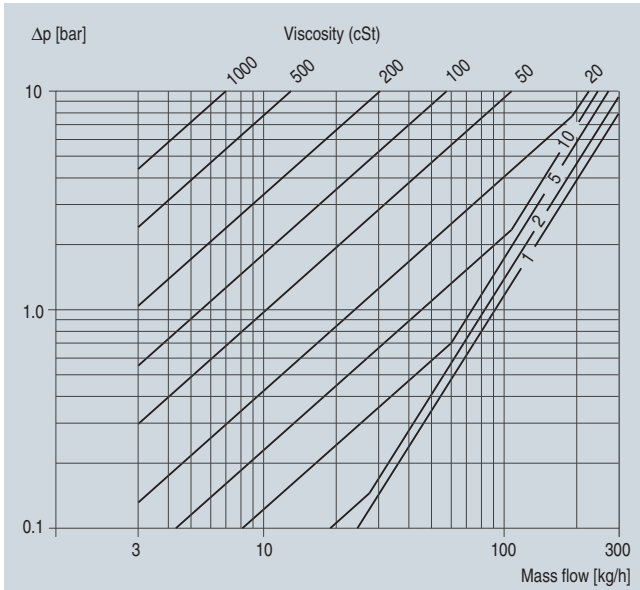

MASS 2100 DI 3 (1/8"), pressure drop for density = 1000 kg/m<sup>3</sup>

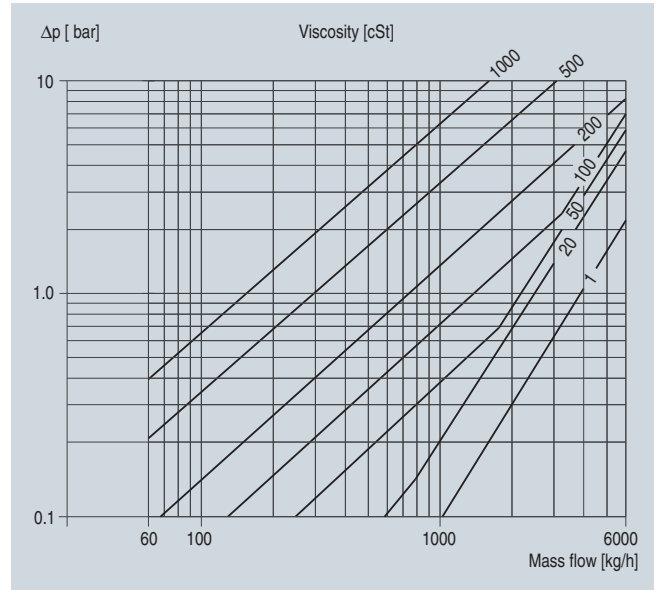

MASS 2100 DI 15 (1/2"), pressure drop for density = 1000 kg/m<sup>3</sup>

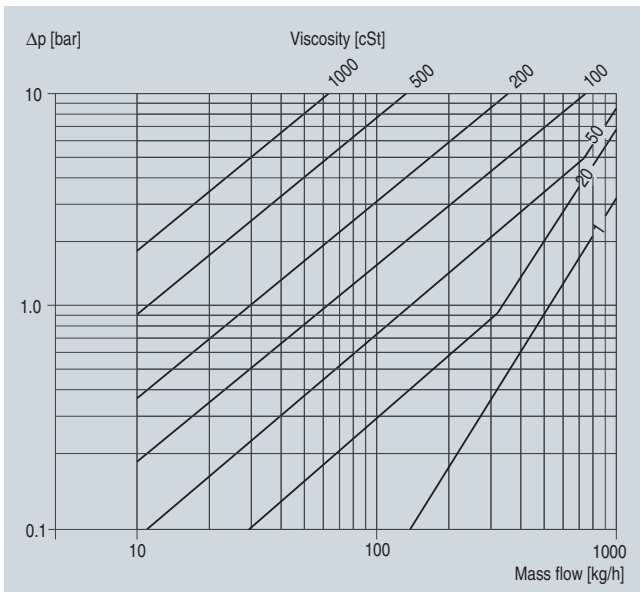

MASS 2100 DI 6 (1/4"), pressure drop for density = 1000 kg/m<sup>3</sup>

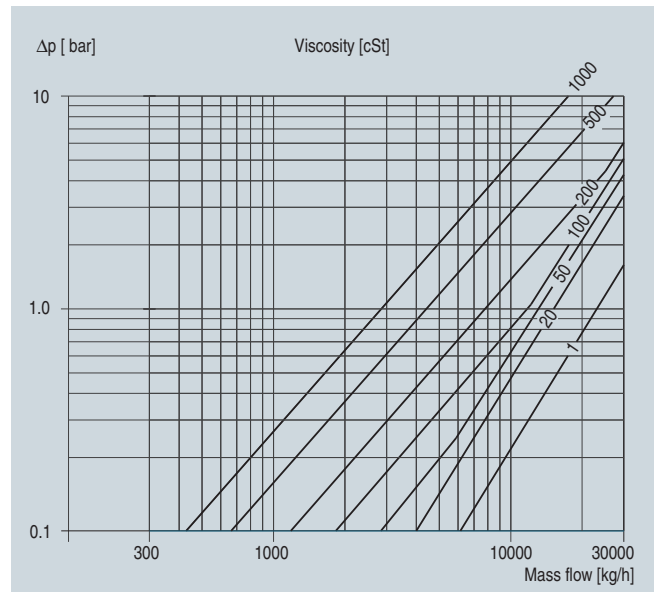

MASS 2100 DI 25 (1"), pressure drop for density = 1000 kg/m<sup>3</sup>

# SITRANS F flowmeters

## SITRANS F C

### MASS 2100 DI 3 to DI 40

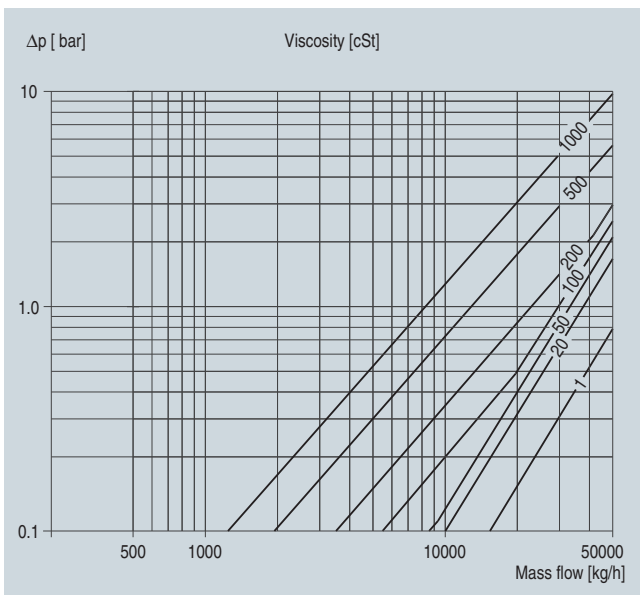

MASS 2100 DI 40 (1½"), pressure drop for density = 1000 kg/m<sup>3</sup>

# SITRANS F flowmeters

## SITRANS F C

**MASS 2100 DI 3 to DI 40**

Selection and Ordering data	Order No.	Order code
<b>SITRANS F C sensors</b>		
<b>MASS 2100 without heating jacket</b>	7ME4100-	
<b>MASS 2100 heated, DN 15 connection</b>	7ME4200-	
<b>MASS 2100 heated, ½ inch, ANSI B16.5 connection</b>	7ME4210-	
<b>Diameter</b>		
Stainless steel 1.4435/316L		
DI 3 (PN 100/PN 230)	1C	
DI 6	1D	
DI 15	1E	
DI 25	1F	
DI 40	1G	
2.4602/Hastelloy C22		
DI 3 (PN 100/PN 350)	2C	
DI 6	2D	
DI 15	2E	
DI 25	2F	
<b>Pressure</b>		
PN 16 (DI 6, DI 15, DI 25 and DI 40)	A	
PN 25 (DI 6, DI 15, DI 25 and DI 40)	B	
PN 40 (DI 6, DI 15, DI 25 and DI 40)	C	
PN 100 (DI 3, DI 6, DI 15, DI 25 and DI 40)	D	
PN 105 (DI 40, 2", 316L)	E	
PN 110 (DI 25, 1", 316L)	F	
PN 130 (DI 15, ½", 316L)	G	
PN 185 (DI 25, 1", Hastelloy C-22)	J	
PN 200 (DI 15, ½", Hastelloy C-22)	K	
PN 230 (DI 3, ¼", 316L)	L	
PN 265 (DI 6, ¼", 316L)	M	
PN 350 (DI 3, ¼", Hastelloy C-22)	N	
PN 410 (DI 6, ¼", Hastelloy C-22)	Q	
Class 150 (DI 6, DI 15, DI 25 and DI 40)	R	
Class 600 (DI 6, DI 15, DI 25 and DI 40)	S	
<b>Process connection/flange</b>		
Pipe thread		
G ¼"	10	
¼" NPT	11	
G ½"	12	
½" NPT	13	
G 1	14	
1" NPT	15	
G 2"	16	
2" NPT	17	
Flange EN1092-1 Form B		
DN 10 (PN 40/PN 100)	20	
DN 15 (PN 40/PN 100)	21	
DN 25 (PN 40/PN 100)	22	
DN 40 (PN 40/PN 100)	23	
DN 50 (PN 40/PN 100)	24	
Flange ASME/ANSI B 16.5		
½" (class 150/class 600)	30	
¾" (class 150/class 600)	31	
1" (class 150/class 600)	32	
1 ½" (class 150/class 600)	33	
2" (class 150/class 600)	34	

Please also see [www.siemens.com/SITRANSFordering](http://www.siemens.com/SITRANSFordering) for practical examples of ordering

Selection and Ordering data	Order No.	Order code
<b>SITRANS F C sensors</b>		
<b>MASS 2100 without heating jacket</b>	7ME4100-	
<b>MASS 2100 heated, DN 15 connection</b>	7ME4200-	
<b>MASS 2100 heated, ½ inch, ANSI B16.5 connection</b>	7ME4210-	
<b>Dairy screwed connection DIN 11851</b>		
DN 10 (PN 40)	40	
DN 15 (PN 40)	41	
DN 25 (PN 40)	42	
DN 32 (PN 40)	43	
DN 40 (PN 25)	44	
DN 50 (PN 25)	45	
DN 65 (PN 25)	46	
<b>Dairy clamp connection ISO 2852</b>		
Cone down the sensor in order to obtain self drainage with connectors ISO 2852		
25 mm (PN 16)	50	
38 mm (PN 16)	51	
51 mm (PN 16)	52	
<b>Dairy screwed connection ISO 2853</b>		
25 mm (PN 16)	60	
38 mm (PN 16)	61	
51 mm (PN 16)	62	
<b>Configuration/calibration type</b>		
Standard	1	
Density	2	
Brix/Plato	3	
Fraction (specification required)	9	N O Y
<b>Transmitter compact mounted on sensor</b>		
No transmitter, sensor only	A	
MASS 6000, Ex d, stainless steel enclosure, 1 current, 1 freq./pulse and 1 relay output, 24 V AC/DC with EEx-de [ia/ib] T3 -T6 Ex-approval.	B	
MASS 6000, IP67, Polyamide enclosure, cable glands M20, 1 current, 1 freq./pulse and 1 relay output, 24 V AC/DC.	C	
MASS 6000, IP67, Polyamide enclosure, cable glands M20, 1 current, 1 freq./pulse and 1 relay output, 115/230 V AC 50/60 Hz	D	
MASS 6000, IP67, Polyamide enclosure, cable glands ½" NPT, 1 current, 1 freq./pulse and 1 relay output, 24 V AC/DC	E	
MASS 6000, IP67, Polyamide enclosure, cable glands ½" NPT, 1 current, 1 freq./pulse and 1 relay output, 115/230 V AC 50/60 Hz, ½" NPT	F	
<b>Cable</b>		
No cable	A	
5 m (16 ft) cable	B	
10 m (32 ft) cable	C	
25 m (82 ft) cable	D	
50 m (164 ft) cable	E	
75 m (246 ft) cable	F	
150 m (492 ft) cable	G	
<b>Calibration/verification</b>		
Standard calibration 3 flow x 2 points	1	
Stand. calibration matched pair 3 flow x 2 points	2	
Accredited calibration matched pair 5 flow x 2 points (DANAK)	3	
Extended calibration customer specified select Y60, Y61, Y62 or Y63 (see additional information)	8	

# SITRANS F flowmeters

## SITRANS F C

### MASS 2100 DI 3 to DI 40

#### Dairy MLFB example

##### MASS 2100

Sensor size DI 15, 1.4435/316L  
 PN 40  
 DN 15 connector  
 Standard configuration/calibration  
 MASS 6000 IP67 compact mounted  
 No cable  
 Standard calibration, 3 flow x 2 points

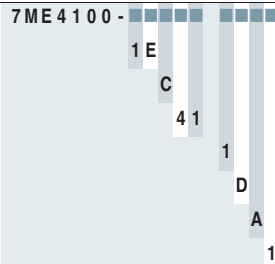

#### Selection and Ordering data

Order code

#### Additional information

Please add "-Z" to Order No. and specify Order code(s) and plain text.

Pressure testing certificate PED: 97/23/EC	<b>C11</b>
Material certificate EN 10204-3.1B	<b>C12</b>
Welding certificate NDT X-ray: EN 25817/B DI 3 sensor only: NDT-Penetrant: ISO 3452	<b>C13</b>
Factory certificate according to EN 10204 2.2	<b>C14</b>
Factory certificate according to EN 10204 2.1	<b>C15</b>
Tag name plate, stainless steel	<b>Y17</b>
Tag name plate, plastic	<b>Y18</b>
Customer specific transmitter setup	<b>Y20</b>
Customer specified, matched pair (5x2)	<b>Y60</b>
Customer specified calibration (5x2)	<b>Y61</b>
Customer specified, matched pair (10x1)	<b>Y62</b>
Customer specified calibration (10x1)	<b>Y63</b>
Special version	<b>Y99</b>

#### Selection and Ordering data

##### Accessories

Description	Dimension	Order No.
Mating parts for hygienic fittings DIN 11851	DN 10 DN 15	<b>FDK-085U1016</b> <b>FDK-085U1017</b>
Includes:	DN 25	<b>FDK-085U1019</b>
• 2 unions	DN 32	<b>FDK-085U1020</b>
• 2 mating parts (for welding in)	DN 40	<b>FDK-085U1021</b>
• 2 EPDM gaskets	DN 50	<b>FDK-085U1022</b>
	DN 65	<b>FDK-085U1023</b>
Mating parts for hygienic clamp ISO 2852	25 mm 40 mm 50 mm	<b>FDK-085U1029</b> <b>FDK-085U1031</b> <b>FDK-085U1032</b>
Includes:		
• 2 clamps		
• 2 mating parts		
• 2 EPDM gaskets		

##### Gaskets for MASS 2100

Description	Dimension	Order No.
2 EPDM gaskets with collar for mounting set DIN 11851	DN 10 DN 15 DN 25 DN 32 DN 40 DN 50 DN 65	<b>FDK-085U1006</b> <b>FDK-085U1007</b> <b>FDK-085U1009</b> <b>FDK-085U1010</b> <b>FDK-085U1011</b> <b>FDK-085U1012</b> <b>FDK-085U1013</b>

##### Spare parts

Description	Length	Order No.
<b>Cable with multiple plug</b>	5 m (16.4 ft)	<b>FDK-083H3015</b>
Standard blue cable between MASS 6000 and MASS 2100, 5 x 2 x 0.34 mm <sup>2</sup> twisted and screened in pairs.	10 m (32.8 ft)	<b>FDK-083H3016</b>
Temperature range -20 °C ... +110 °C (-4 °F ... +230 °F)	25 m (82 ft)	<b>FDK-083H3017</b>
	50 m (164 ft)	<b>FDK-083H3018</b>
	75 m (246 ft)	<b>FDK-083H3054</b>
	150 m (492 ft)	<b>FDK-083H3055</b>
<b>Adapter for MASS 2100</b>		<b>FDK-083L8889</b>
<b>Multiple plug for cable mounting</b>		<b>FDK-083H5056</b>
<b>2 kB SENSORPROM unit</b> (Sensor Serial No. and Order No. must be specified by ordering)		<b>FDK-083H4410</b>

## Dimensional drawings

## MASS 2100 sensor

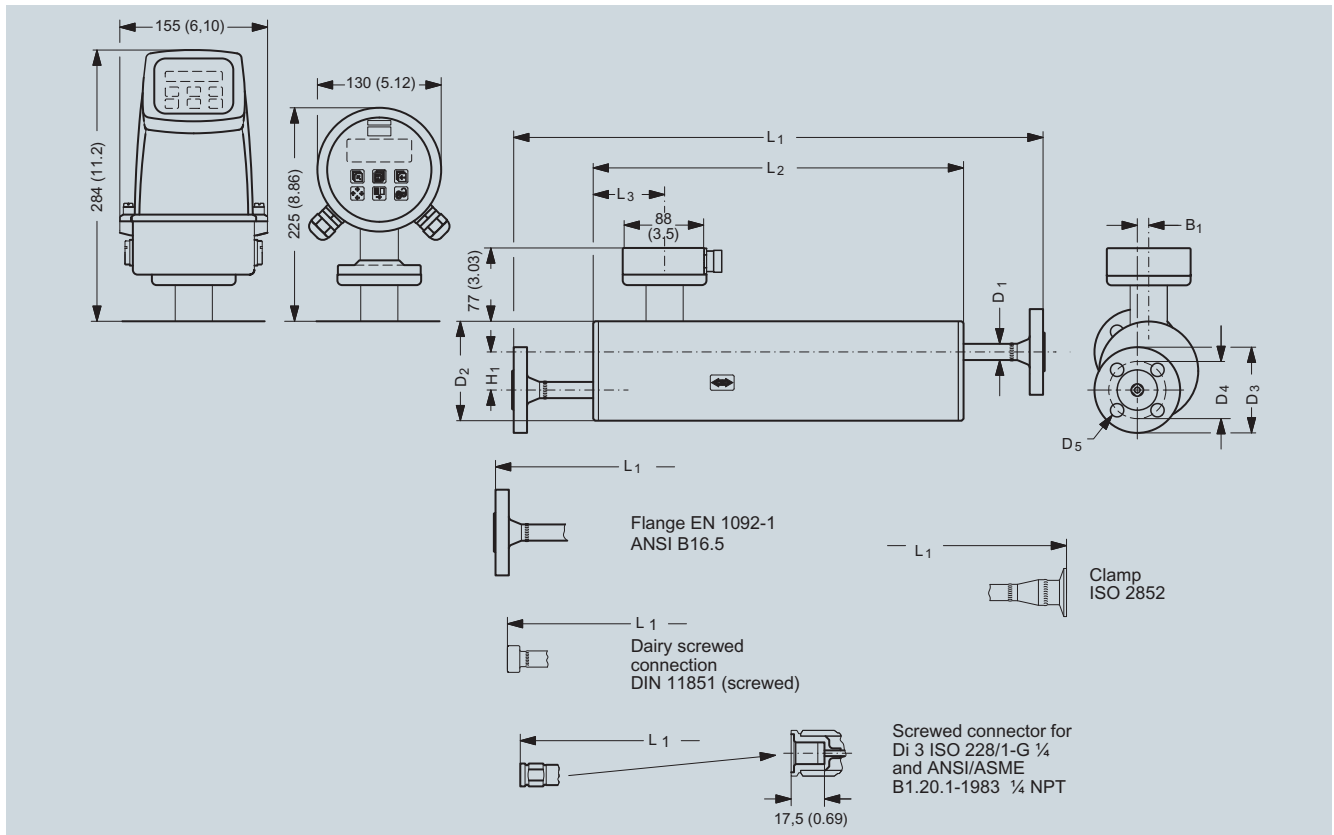

Dimension in mm (inch)

Sensor size	Connections			L1 mm	L2 mm	L3 mm	H1 mm	B1 mm	D1 mm	D2 mm	D3 mm	D4 mm	D5 mm
DI (inch)	Type	Pressure rating	Size										
DI 3 (1/8")	Pipe thread ISO 228/1 - G 1/4	PN 100	1/4"	400	280	75.0	60	0	21.3	104	-	-	-
	Pipe thread ANSI/ASME B 1.20.1 - 1/4" NPT	PN 100	1/4"	400	280	75.0	60	0	21.3	104	-	-	-
DI 6 (1/4")	Flange EN 1092-1	PN 40	DN 10	560	390	62.0	40	12	17.0	104	90.0	60.0	14.0
	Flange ANSI B16.5	Class 150	1/2"	624	390	62.0	40	12	17.0	104	88.9	60.5	15.7
	Flange ANSI B16.5	Class 600	1/2"	608	390	62.0	40	12	17.0	104	95.3	66.5	15.7
	Screwed connection DIN 11851	PN 40	DN 10	532	390	62.0	40	12	17.0	104	-	-	-
	Clamp ISO 2852	PN 16	25 mm	570	390	62.0	40	12	17.0	104	-	-	-
DI 15 (1/2")	Flange EN 1092-1	PN 40	DN 15	620	444	75.0	44	20	21.3	129	95.0	65.0	14.0
	Flange ANSI B16.5	Class 150	1/2"	639	444	75.0	44	20	21.3	129	88.9	60.5	15.7
	Flange ANSI B16.5	Class 600	1/2"	660	444	75.0	44	20	21.3	129	95.3	66.5	15.7
	Screwed connection DIN 11851	PN 40	DN 15	586	444	75.0	44	20	21.3	129	-	-	-
	Clamp ISO 2852	PN 16	25 mm	624	444	75.0	44	20	21.3	129	-	-	-
DI 25 (1")	Flange EN 1092-1	PN 40	DN 25	934	700	74.5	126	25	33.7	219	115.0	85.0	14.0
	Flange ANSI B16.5	Class 150	1"	967	700	74.5	126	25	33.7	219	108.0	79.2	15.7
	Flange ANSI B16.5	Class 600	1"	992	700	74.5	126	25	33.7	219	124.0	88.9	19.1
	Screwed connection DIN 11851	PN 40	DN 32	922	700	74.5	126	25	33.7	219	-	-	-
	Clamp ISO 2852	PN 16	38 mm	940	700	74.5	126	25	33.7	219	-	-	-
DI 40 (1 1/2")	Flange EN 1092-1	PN 40	DN 40	1064	850	71.5	180	0	48.3	273	150.0	110.0	18.0
	Flange ANSI B16.5	Class 150	1 1/2"	1100	850	71.5	180	0	48.3	273	127.0	98.6	15.7
	Flange ANSI B16.5	Class 600	1 1/2"	1128	850	71.5	180	0	48.3	273	155.4	114.3	22.4
	Screwed connection DIN 11851	PN 25	DN 50	1090	850	71.5	180	0	48.3	273	-	-	-
	Clamp ISO 2852	PN 25	51 mm	1062	850	71.5	180	0	48.3	273	-	-	-

# SITRANS F flowmeters

## SITRANS F C

### MASS 2100 DI 3 to DI 40

Sensor size	Connections			L1	L2	L3	H1	B1	D1	D2	D3	D4	D5
				inch	inch	inch	inch	inch	inch	inch	inch	inch	inch
DI (inch)	Type	Pressure rating	Size										
DI 3 (1/8")	Pipe thread ISO 228/1 - G 1/4	PN 100	1/4"	15.75	11.02	2.95	2.36	0	0.84	4.09	-	-	-
	Pipe thread ANSI/ASME B 1.20.1 - 1/4" NPT	PN 100	1/4"	15.75	11.02	2.95	2.36	0	0.84	4.09	-	-	-
DI 6 (1/4")	Flange EN 1092-1	PN 40	DN 10	22.05	15.35	2.44	1.57	0.47	0.67	4.09	3.54	2.36	0.55
	Flange ANSI B16.5	Class 150	1/2"	24.57	15.35	2.44	1.57	0.47	0.67	4.09	3.5	2.38	0.62
	Flange ANSI B16.5	Class 600	1/2"	23.94	15.35	2.44	1.57	0.47	0.67	4.09	3.75	2.62	0.62
	Screwed connection DIN 11851	PN 40	DN 10	20.94	15.35	2.44	1.57	0.47	0.67	4.09	-	-	-
	Clamp ISO 2852	PN 16	25 mm	22.44	15.35	2.44	1.57	0.47	0.67	4.09	-	-	-
DI 15 (1/2")	Flange EN 1092-1	PN 40	DN 15	24.41	17.48	2.95	1.73	0.79	0.84	5.08	3.74	2.56	0.55
	Flange ANSI B16.5	Class 150	1/2"	25.16	17.48	2.95	1.73	0.79	0.84	5.08	3.5	2.38	0.62
	Flange ANSI B16.5	Class 600	1/2"	25.98	17.48	2.95	1.73	0.79	0.84	5.08	3.75	2.62	0.62
	Screwed connection DIN 11851	PN 40	DN 15	23.07	17.48	2.95	1.73	0.79	0.84	5.08	-	-	-
	Clamp ISO 2852	PN 16	25 mm	24.57	17.48	2.95	1.73	0.79	0.84	5.08	-	-	-
DI 25 (1")	Flange EN 1092-1	PN 40	DN 25	36.77	27.56	2.93	4.96	0.98	1.33	8.62	4.53	3.35	0.55
	Flange ANSI B16.5	Class 150	1"	38.07	27.56	2.93	4.96	0.98	1.33	8.62	4.25	3.12	0.62
	Flange ANSI B16.5	Class 600	1"	39.06	27.56	2.93	4.96	0.98	1.33	8.62	4.88	3.50	0.75
	Screwed connection DIN 11851	PN 40	DN 32	36.30	27.56	2.93	4.96	0.98	1.33	8.62	-	-	-
	Clamp ISO 2852	PN 16	38 mm	37.01	27.56	2.93	4.96	0.98	1.33	8.62	-	-	-
DI 40 (1 1/2")	Flange EN 1092-1	PN 40	DN 40	41.89	33.46	2.81	7.09	0	1.9	10.75	5.91	4.33	0.71
	Flange ANSI B16.5	Class 150	1 1/2"	43.31	33.46	2.81	7.09	0	1.9	10.75	5	3.88	0.62
	Flange ANSI B16.5	Class 600	1 1/2"	44.41	33.46	2.81	7.09	0	1.9	10.75	6.12	4.50	0.88
	Screwed connection DIN 11851	PN 25	DN 50	42.91	33.46	2.81	7.09	0	1.9	10.75	-	-	-
	Clamp ISO 2852	PN 25	51 mm	41.81	33.46	2.81	7.09	0	1.9	10.75	-	-	-

## MASS 2100 sensor with "heating jacket"

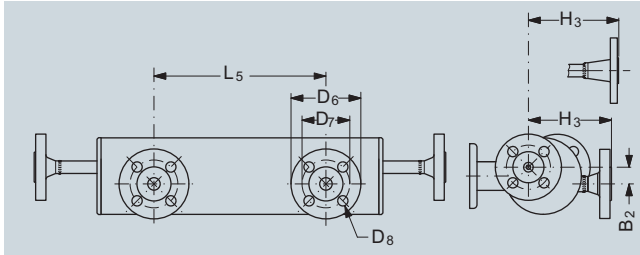

Dimensions in mm (inch)

Sensor size	Connec- tions heated			L5	L3	H3	B2	D6	D7	D8
DI (inch)	Type	Pressure rating	Size	mm (inch)	mm (inch)	mm (inch)	mm (inch)	mm (inch)	mm (inch)	mm (inch)
DI 3 (1/8")	EN 1092-1	PN 40	DN 15	234 (9.21)	75 (2.95)	122 (4.8)	22 (0.87)	95 (3.74)	65.0 (2.56)	14.0 (0.55)
	ANSI B16.5	Class 150	1/2"	234 (9.21)	75 (2.95)	131.6 (5.18)	22 (0.87)	88.9 (3.5)	60.5 (2.38)	15.7 (0.62)
DI 6 (1/4")	EN 1092-1	PN 40	DN 15	234 (9.21)	62 (2.44)	112 (4.41)	22.7 (0.89)	95 (3.74)	65.0 (2.56)	14.0 (0.55)
	ANSI B16.5	Class 150	1/2"	234 (9.21)	62 (2.44)	121.6 (4.79)	22.7 (0.89)	88.9 (3.5)	60.5 (2.38)	15.7 (0.62)
DI 15 (1/2")	EN 1092-1	PN 40	DN 15	234 (9.21)	75 (2.95)	126.5 (4.98)	31.5 (1.24)	95 (3.74)	65.0 (2.56)	14.0 (0.55)
	ANSI B16.5	Class 150	1/2"	234 (9.21)	75 (2.95)	136.1 (5.36)	31.5 (1.24)	88.9 (3.5)	60.5 (2.38)	15.7 (0.62)
DI 25 (1")	EN 1092-1	PN 40	DN 15	420 (16.54)	75 (2.93)	213.6 (8.41)	60 (2.36)	95 (3.74)	65.0 (2.56)	14.0 (0.55)
	ANSI B16.5	Class 150	1/2"	420 (16.54)	75 (2.93)	223.2 (8.79)	60 (2.36)	88.9 (3.5)	60.5 (2.38)	15.7 (0.62)
DI 40 (1 1/2")	EN 1092-1	PN 40	DN 15	500 (19.68)	71 (2.81)	267.5 (10.53)	43 (1.69)	95 (3.74)	65.0 (2.56)	14.0 (0.55)
	ANSI B16.5	Class 150	1/2"	500 (19.68)	71 (2.81)	277.1 (10.91)	43 (1.69)	88.9 (3.5)	60.5 (2.38)	15.7 (0.62)

## MASS 2100 and MASS 6000 Ex d compact version

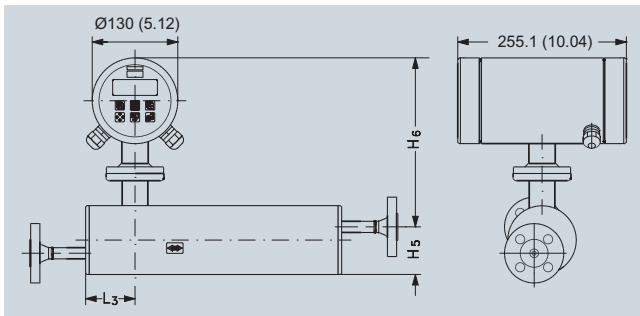

Dimensions in mm (inch)

Sensor size [DI (inch)]	L <sub>3</sub> [mm (inch)]	H <sub>5</sub> [mm (inch)]	H <sub>6</sub> [mm (inch)]	H <sub>5</sub> + H <sub>6</sub> [mm (inch)]
3 (1/8)	75 (2.95)	82 (3.23)	247 (9.72)	329 (12.95)
6 (1/4)	62 (2.44)	72 (2.83)	257 (10.12)	329 (12.95)
15 (1/2)	75 (2.95)	87 (3.43)	267 (10.51)	354 (13.94)
25 (1)	75 (2.95)	173 (6.81)	271 (10.67)	444 (17.48)
40 (1 1/2)	75 (2.95)	227 (8.94)	271 (10.67)	498 (19.61)

## MASS 2100 and MASS 6000 IP67 compact version

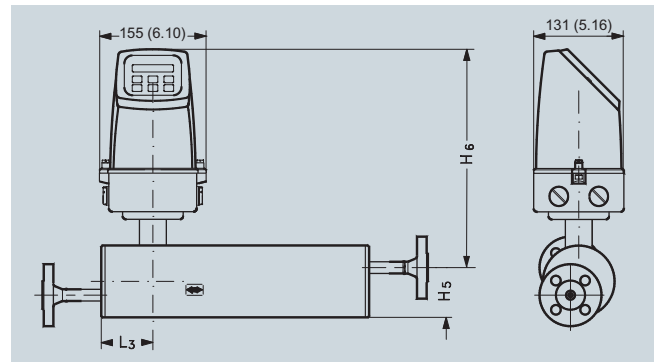

Dimensions in mm (inch)

Sensor size [DI (inch)]	L <sub>3</sub> [mm (inch)]	H <sub>5</sub> [mm (inch)]	H <sub>6</sub> [mm (inch)]	H <sub>5</sub> + H <sub>6</sub> [mm (inch)]
3 (1/8)	75 (2.95)	82 (3.23)	306 (12.04)	388 (15.28)
6 (1/4)	62 (2.44)	72 (2.83)	316 (12.44)	388 (15.28)
15 (1/2)	75 (2.95)	87 (3.43)	326 (12.83)	413 (16.26)
25 (1)	75 (2.95)	173 (6.81)	330 (13.00)	503 (19.80)
40 (1 1/2)	75 (2.95)	227 (8.94)	330 (13.00)	557 (21.93)