

SITRANS F flowmeters

SITRANS F C

SITRANS F C MC2

Overview



SITRANS F C MC2 is available as a standard version (DN 50 to DN 150 (2" to 6")) and a hygienic, EHEDG certified version (DN 20 to DN 80 (¾" to 3")). MC2 and MC2 hygienic are suitable for accurate mass flow measurement of a variety of liquids and gases.

The sensor offers superior performance in terms of flow accuracy, turn-down range and density accuracy and delivers true multi parameter measurements i.e.: mass flow, volume flow, density, temperature and fraction flow.

The very compact sensor construction makes installation and commissioning of even the largest sizes very straight forward and easy.

Benefits

- High accuracy better than 0.15% of mass flow rate
- Large dynamic turn down range
- Densitometer performance available through a density accuracy better than 0.001 g/cm³
- Space saving split-flow sensor design facilitating low pressure loss
- Parallel S-tube design and optimal oriented inductive sensors enhances accuracy and turn-down range
- Self draining in both horizontal and vertical position
- Rigid enclosure design reduces the influence from pipeline vibration and thermal stress
- 4-wire Pt100 temperature measurement ensures optimum accuracy on mass flow, density and fraction flow
- SENSORPROM enables true "plug & play". Installation and commissioning in less than 10 min.
- Safe Ex-design EEx em [ib] IIC
- Sensor pipe available in high quality AISI 316L stainless steel 1.4571 or Hastelloy C 4 2.4610 offering optimum corrosion resistance
- The sensor calibration factor is also valid for gas measurement

Application

Coriolis mass flowmeters are suitable for measuring all liquids and gases. The measurement is independent of changes in process conditions/parameters such as temperature, density, pressure, viscosity, conductivity and flow profile.

Due to this versatility the meter is easy to install and the coriolis flowmeter is recognized for its high accuracy in a wide turn-down range which is a paramount in many applications.

The main applications of the coriolis flowmeter can be found in all industries, such as:

Chemical & pharma	Detergents, bulk chemicals, pharmaceuticals, acids, alkalis
Food & beverage EDEHG certified	Dairy products, beer, wine, soft-drinks, plato/brix, fruit juices and pulps, bottling, CO ₂ dosing, CIP-liquids
Oil & gas	Gas measurement, furnace control, test separators, LPG, oil bunkering
Water & waste water	Dosing of chemicals for water treatment

The wide variety of combinations and versions from the modular system means that ideal adaptation is possible to each measuring task.

Design

The MC2 sensor consists of 2 parallel measuring pipes, welded directly onto a flow-splitter at each end to eliminate a direct coupling to the process connectors and significantly reduce effects from external vibrations.

The flow-splitters are welded onto a rigid sensor housing which acts as a mechanical low pass filter.

The sensor is available in 2 material configurations, AISI 316L or Hastelloy C4 with a wide variety of process connections.

The enclosure is made of stainless steel AISI 304 1.4301 with a grade of encapsulation of IP67/NEMA 4.

The sensor is Ex-approved EEx em [ib] IIC

The sensor can be installed in horizontal or vertical position, and is self draining in both positions.

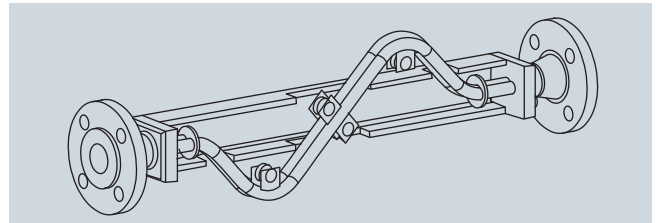

Due to the increased safety concept used on the bigger sized sensors, the MASS 6000 19" or SIFLOW FC070 Ex standard versions can be connected but has to be remote mounted in the safe area. For all non hazardous applications the complete MASS 6000 transmitter program can be used.



Hazardous area
Zone 1 + 2



Safe area

Function

The measuring principle is based on coriolis law of movement, see "System information coriolis mass flowmeters".

Integration*Installation guidelines MC2 DN 50 ... DN 150*Installation of sensor

The optimal installation orientation is a vertical installation with an upward flow as shown in the following figure. This has the advantage that any solids contained in the fluid will settle downward and gas bubbles will move upward out of the meter tube when the flow rate is zero. Additionally, it is easy to drain the meter tube. Deposits can thereby be avoided.

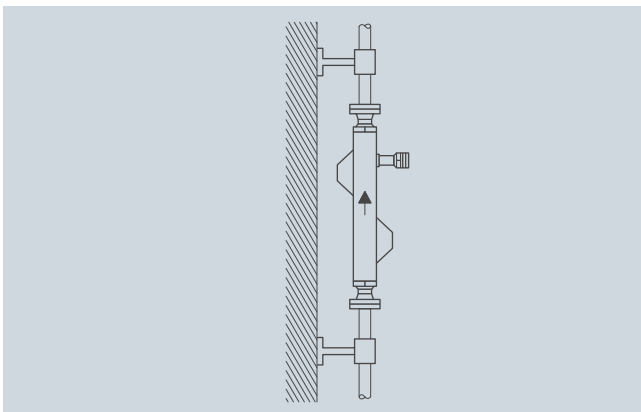
Vertical orientation:

Vertical installation self-draining (upward flow)

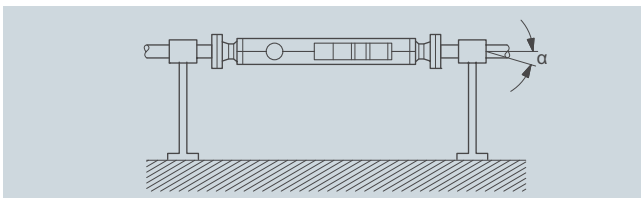
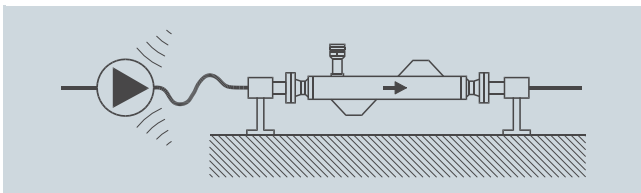
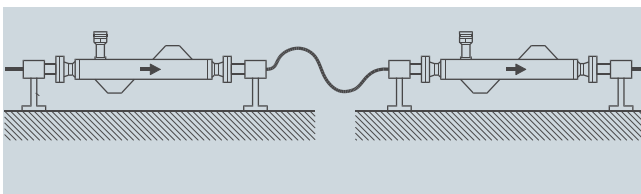
Horizontal orientation, self-drainingAvoid vibrationsAvoid cross talkInstallation in a drop line

Mount with reduction or orifice to prevent partially draining (A) orifice, pipe constriction (B) valve.

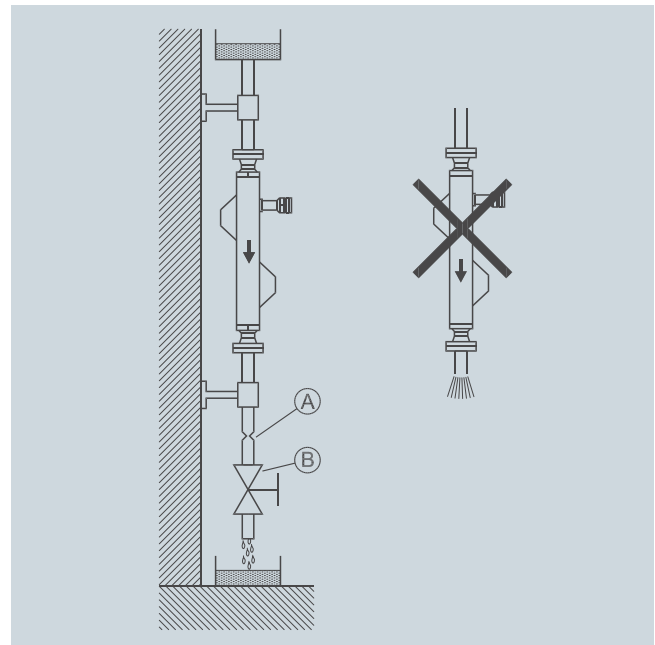

Installation in a drop line

SITRANS F flowmeters

SITRANS F C

SITRANS F C MC2

Technical specifications

Versions	mm (inch)	20 (¾)	25 (1)	40 (1½)	50 (2)	65 (2½)	80 (3)	100 (4)	150 (6)	
Inside pipe diameter	2 x mm (inch)	8.0 (0.31)	10.0 (0.39)	16.0 (0.63)	22.0 (0.87)	29.0 (1.14)	34.0 (1.34)	43.1 (1.69)	76.1 (2.99)	
Pipe wall thickness	mm (inch)	1.0 (0.04)	1.0 (0.04)	1.0 (0.04)	1.5 (0.06)	1.5 (0.06)	2.0 (0.08)	2.6 (0.10)	3.2 (0.13)	
Mass flow measuring range at pressure drop of 2 bar (29 psi) at 1 g/cm³ (0.036 lb/inch³)	kg/h (lb/h)	6 000 (13 227)	9 000 (19 841)	28 500 (62 831)	55 200 (121 695)	113 400 (250 000)	147 600 (325 401)	249 600 (550 273)	660 000 (1 455 049)	
Density	g/cm ³ (lb/inch ³)	0.5 ... 3.5 (0.18 ... 0.126)								
Fraction e.g. Brix	°Brix	0 ... 100								Not possible
Temperature										
Standard-version	°C (°F)	-50 ... +180 °C (-58 ... +356 °F)								
Ex-version	°C (°F)	-20 ... +180 °C (-4 ... +356 °F)								
Liquid pressure measuring pipe		20	25	40						
Stainless steel (DIN 2413, 20 °C (68 °F))	bar (psi)	100 (1450)	100 (1450)	100 (1450)	100 (1450)	100 (1450)	100 (1450)	40 (580)	40 (580)	
Materials										
Measuring pipe		SS 1.4571 or Hastelloy C4								
Flange		SS 1.4571 or Hastelloy C4								
Enclosure		IP67								
Enclosure material/connection box		1.4301/aluminium, max. pressure 40 bar (580 psi)								
Process connections		See dimensional drawings								
Electrical connections		Screw terminals, M 20								
Cable length		5 x 2 x 0.35 mm ² twisted and screened in pairs, ext. Ø 12 mm								
Ex-version										
ATEX 1443X		≤ DN 40: II 1/2 EEx em [ib] IIC T2-T6 ≥ DN 50: II 2G EEx em [ib] IIC T2-T6								
Weight approx.	kg (lb)	13 (28)	14 (31)	18 (40)	34 (75)	47 (104)	58 (128)	91 (201)	261 (573)	

For accuracy specifications see „System information Coriolis mass flow meters“.

Pressure drop

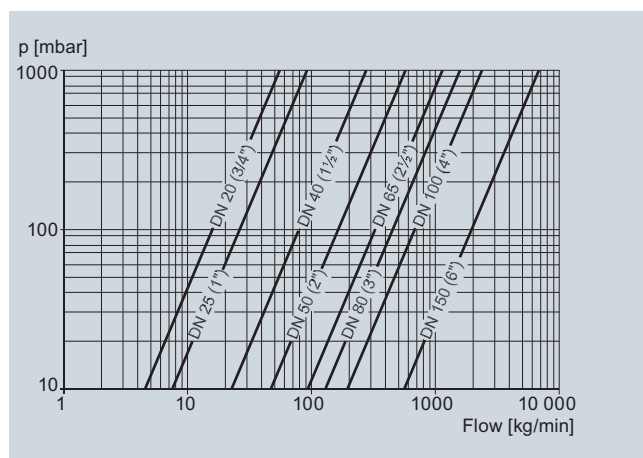

SITRANS F flowmeters

SITRANS F C

SITRANS F C MC2

Selection and Ordering data	Order No.	Order code
SITRANS F C flow sensors MC2	7ME4300-	
Nominal diameter		
W 1.4571/316Ti		
DN 50	1 A	
DN 65	1 B	
DN 80	1 C	
DN 100	1 D	
DN 150	1 E	
Hastelloy C4		
DN 50	2 A	
DN 65	2 B	
DN 80	2 C	
DN 100	2 D	
DN 150	2 E	
Nominal pressure		
PN 40	A	
PN 100	B	
Class 150	C	
Class 300	D	
Class 600	E	
Clamps/screwed-connections	F	
Process connections		
Flange EN 1092-1		
DN 50 (PN 40/PN 100)	2 0	
DN 65 (PN 40/PN 100)	2 1	
DN 80 (PN 40/PN 100)	2 2	
DN 100 (PN 40)	2 3	
DN 150 (PN 40)	2 4	
Flange ASME/ANSI		
2" (class 150/300/600)	3 0	
2 ½" (class 150/300/600)	3 1	
3" (class 150/300/600)	3 2	
4" (class 150/300)	3 3	
6" (class 150/300)	3 4	
Dairy screwed connection to DIN 11851		
DN 50 (PN 25)	4 0	
DN 65 (PN 25)	4 1	
DN 80 (PN 25)	4 2	
DN 100 (PN 25)	4 3	
Dairy clamp connection DIN 32676 Tri-clamp		
50 mm clamp (PN 16)	5 0	
66 mm clamp (PN 10)	5 1	
81 mm clamp (PN 10)	5 2	
100 mm clamp (PN 10)	5 3	
Aseptic nut flange DIN 11864-2 form A for pipes dimensioned by DIN 11866		
DN 40 (1½")	6 0	
DN 50 (2")	6 1	
DN 65 (2½")	6 2	
DN 80 (3")	6 3	
DN 100 (4")	6 4	
Configuration		
Flow and density (5 kg/m ³)	1	
Flow, Brix/Plato and density (1 kg/m ³) ¹⁾	2	
Flow and density (1 kg/m ³) ¹⁾	5	
Flow, fraction (specified by customer) and density (1 kg/m ³) ¹⁾	9	N 0 Y
Ex-approval		
Standard, without explosion protection	A	
With explosion protection: Ex, ATEX, FM Class I, Div 1	B	

Selection and Ordering data	Order No.	Order code
SITRANS F C flow sensors MC2	7ME4300-	
Cable		
No cable (see accessories)		A
Calibration		
Standard		1
Matched pair		2

¹⁾ Extended density and fraction not possible with DN 150

Please also see www.siemens.com/SITRANSOrdering for practical examples of ordering

Dairy MLFB example	Order code
MC2 sensor	7ME4300-
Sensor size DN 80. material 1.4571/316Ti	1 C
Nominal pressure: Clamps DIN 11851, DN 80, PN 25	F 4 2
	
Configuration/calibration type: flow and density (5 kg/m ³)	1
Without Ex approval	A
No cable	A
Standard calibration	1

Selection and Ordering data	Order code
Additional information	
Please add "-Z" to Order No. and specify Order code(s) and plain text.	
Pressure testing certificate PED: 97/23/EC	C11
Material certificate EN 10204-31B	C12
Welding certificate NDT X-ray: EN 25817/B	C13
Factory certificate according to EN 10204 2.2	C14
Factory certificate according to EN 10204 2.1	C15
Tag name plate, stainless steel	Y17
Tag name plate, plastic	Y18
Customer specific transmitter setup	Y20
Customer specified, matched pair (5 x 2)	Y60
Customer specified calibration (5 x 2)	Y61
Customer specified, matched pair (10 x 1)	Y62
Customer specified calibration (10 x 1)	Y63
Special version	Y99

Accessories	Order No.
Description	
Cables from MC2 sensor to MASS 6000 transmitter	
10 m (32 ft)	FDK-083H3001
25 m (80 ft)	FDK-083H3002
75 m (240 ft)	FDK-083H3003
150 m (480 ft)	FDK-083H3004

Spare parts	Order No.
Description	
2 kB SENSORPROM unit (Sensor Serial No. and Order No. must be specified by ordering)	FDK-083H4410

SITRANS F flowmeters

SITRANS F C

SITRANS F C MC2

Selection and Ordering data

Order No. Order code

SITRANS F C flow sensors MC2 for Hygienic applications only

7ME4310 -

Nominal diameter

W 1.4435/316L

DN 20

1 A

DN 25

1 B

DN 40

1 C

DN 50

1 D

DN 65

1 E

DN 80

1 F

Nominal pressure 40 bar, PN 25

Clamps/screwed-connections

F

Pressure and Process connections

Dairy screwed connection to DIN 11851

DN 20 (¾"), PN 25

4 0

DN 25 (1"), PN 25

4 1

DN 40 (1½"), PN 25

4 2

DN 50 (2"), PN 25

4 3

DN 65 (2½"), PN 25

4 4

DN 80 (3"), PN 25

4 5

Dairy clamp connectors for DIN 32676

Tri-clamp

20 mm clamp

4 7

26 mm clamp

4 8

38 mm clamp

4 9

50 mm clamp

5 0

66 mm clamp

5 1

81 mm clamp

5 2

Aseptic connectors DIN 11864-2 Form A for

DIN tubes

DN 20

5 8

DN 25

5 9

DN 40

6 0

DN 50

6 1

DN 65

6 2

DN 80

6 3

Configuration

Flow and density (5 kg/m³)

1

Flow, Brix/Plato and density (5 kg/m³)¹⁾

2

Flow and density (1 kg/m³)¹⁾

5

Flow, fraction (customer specified application form the net)

9

N 0 Y

Ex-approval

Standard, without explosion protection

A

With explosion protection: Ex, ATEX, FM Class I, Div 1

B

Cable

No cable (see accessories)

A

Calibration

Standard

1

Matched pair

2

¹⁾ Extended density and fraction not possible with DN 150

Please also see www.siemens.com/SITRANSOrdering for practical examples of ordering

Selection and Ordering data

Order code

Additional information

Please add "-Z" to Order No. and specify Order code(s) and plain text.

Pressure testing certificate PED: 97/23/EC

C11

Material certificate EN 10204-31B

C12

Welding certificate NDT X-ray: EN 25817/B

C13

Factory certificate according to EN 10204 2.2

C14

Factory certificate according to EN 10204 2.1

C15

Tag name plate, stainless steel

Y17

Tag name plate, plastic

Y18

Customer specific transmitter setup

Y20

Customer specified, matched pair (5x2)

Y60

Customer specified calibration (5x2)

Y61

Customer specified, matched pair (10x1)

Y62

Customer specified calibration (10x1)

Y63

Special version

Y99

Accessories

Description

Order No.

Cables from MC2 sensor to MASS 6000 transmitter

10 m (32 ft)

FDK-083H3001

25 m (80 ft)

FDK-083H3002

75 m (240 ft)

FDK-083H3003

150 m (480 ft)

FDK-083H3004

Spare parts

Description

Order No.

2 kB SENSORPROM unit

(Sensor Serial No. and Order No. must be specified by ordering)

FDK-083H4410

Dairy MLFB example

MC2 sensor

Sensor size DN40
material 1.4435/316L

Nominal pressure: Clamp

DIN 11851, DN 40, PN 25



Configuration/calibration type: flow
and density (5 kg/m³)

Without Ex approval

No cable

Standard calibration

7ME4310 -

1 C

F

4 2

1

A

A

1

Dimensional drawings

Remote design, flanged construction, DIN/ANSI

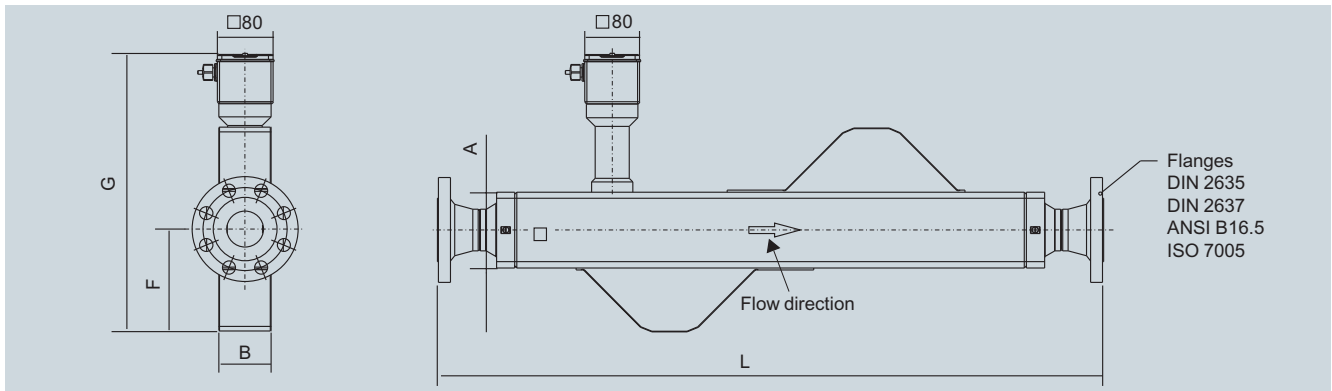

Meter size		Process connection size		L [mm (inch)]						G ¹⁾ [mm (inch)]	F [mm (inch)]	B [mm (inch)]	A [mm (inch)]	Weight kg
Inch	DN	Inch	DN	DIN 11864-2 form A	DIN 2635 PN 40	DIN 2637 PN 100	ANSI CL 150	ANSI CL 300	ANSI CL 600					
2	50	2	50	918 (36.14)	940 (37.01)	979 (38.54)	970 (38.19)	980 (38.58)	1001 (39.41)	403 (15.87)	148 (5.83)	80 (3.15)	110 (4.33)	34
		2½	65	1081 (42.56)	1100 (43.31)	1148 (45.20)	1218 (47.95)	1228 (48.35)	1248 (49.13)					38
2½	65	2	50	1197 (47.13)	1220 (48.03)	1259 (49.57)	1250 (49.21)	1260 (49.61)	1281 (50.43)	429 (16.89)	164 (6.64)	97 (3.82)	130 (5.12)	43
		2½	65	1081 (42.56)	1100 (43.31)	1148 (45.20)	1218 (47.95)	1228 (48.35)	1249 (49.17)					47
		3	80	1200 (47.24)	1220 (48.03)	1260 (49.61)	1240 (48.82)	1260 (49.61)	1282 (50.47)					50
3	80	2½	65	1310 (51.57)	1330 (52.36)	1378 (54.25)	1365 (53.74)	1375 (54.13)	1396 (54.96)	456 (17.95)	186 (7.32)	108 (4.25)	140 (5.51)	56
		3	80	1200 (47.24)	1220 (48.03)	1260 (49.61)	1240 (48.82)	1260 (49.61)	1282 (50.47)					58
		4	100	1463 (57.60)	1480 (58.27)	1530 (60.24)	1500 (59.06)	1520 (59.84)	1568 (61.73)					69
4	100	3	80	1618 (63.70)	1640 (64.57)	1680 (66.14)	1660 (65.35)	1680 (66.14)	1702 (67.01)	500 (19.69)	215 (8.46)	131 (5.16)	170 (6.69)	84
		4	100	1463 (57.60)	1480 (58.27)	1530 (60.24)	1500 (59.06)	1520 (59.84)	1568 (61.73)					91
		6	150	N/A	1778 (69.92)	N/A	1806 (71.10)	1826 (71.89)	N/A					120
6	150	6	150	N/A	2040 (80.31)	N/A	2070 (81.50)	2090 (82.28)	N/A	613 (24.13)	285 (11.22)	190 (7.84)	260 (9.84)	260

1) For EEx add 54 mm

Remote design, food industry fittings, DIN 11851

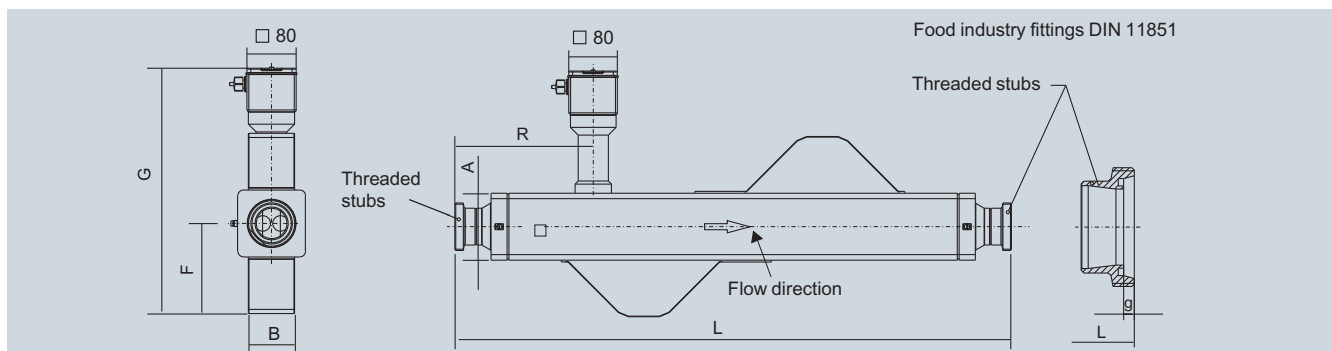

Meter size		Process connection size		L [mm (inch)]	g [mm (inch)]	G ¹⁾ [mm (inch)]	F [mm (inch)]	B [mm (inch)]	A [mm (inch)]	R [mm (inch)]	Weight kg	
Inch	DN	Inch	DN									
2	50	2	50	Rd 78 x 1/6	918 (36.14)	7 (0.28)	403 (15.87)	148 (5.83)	80 (3.15)	110 (4.33)	177 (6.97)	30
		2½	65	Rd 95 x 1/6	1081 (42.56)	8 (0.31)					254 (10.00)	34
2½	65	2	50	Rd 78 x 1/6	1197 (47.13)	7 (0.28)	429 (16.89)	164 (6.46)	97 (3.82)	130 (5.12)	291 (11.46)	40
		2½	65	Rd 95 x 1/6	1081 (42.56)	8 (0.31)					227 (10.91)	44
		3	80	Rd 110 x 1/6	1200 (47.24)	8 (0.31)					281 (11.06)	47
3	80	2½	65	Rd 95 x 1/6	1310 (51.57)	8 (0.31)	456 (17.95)	186 (7.32)	108 (4.25)	140 (5.51)	319 (12.56)	54
		3	80	Rd 110 x 1/6	1200 (47.24)	8 (0.31)					258 (10.16)	56
		4	100	Rd 110 x 1/6	1463 (57.60)	10 (0.39)					381 (15.00)	60
4	100	3	80	Rd 110 x 1/6	1618 (63.70)	8 (0.31)	500 (19.69)	215 (8.46)	131 (5.16)	170 (6.69)	401 (15.79)	82
		4	100	Rd 130 x ¼	1463 (57.60)	10 (0.39)					314 (12.36)	86

1) For EEx add 54 mm

SITRANS F flowmeters

SITRANS F C

SITRANS F C MC2

Remote design, Tri-clamp DIN 32676 (ISO 2852)

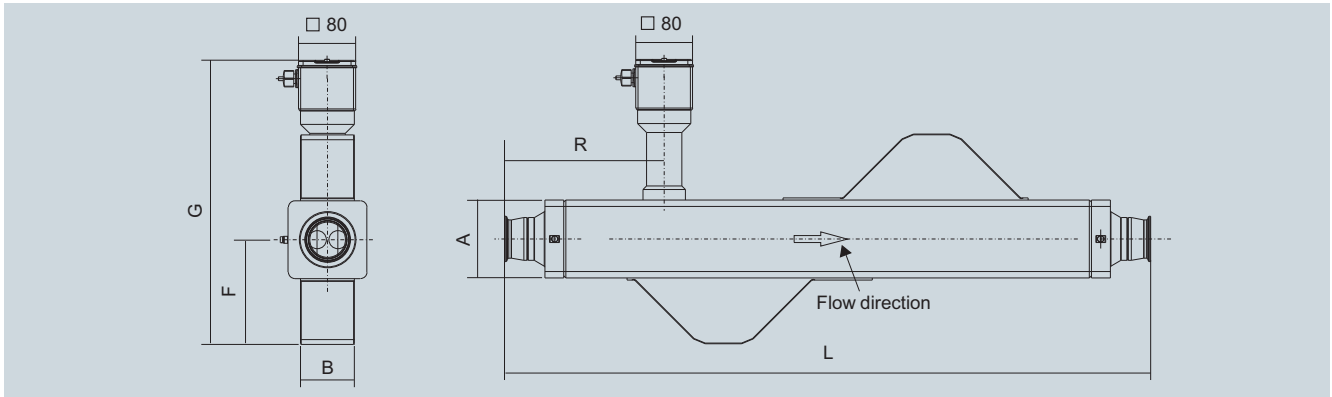

Dimensions in mm (inch)

Meter size		Process connection size		L [mm (inch)] ± 3	G ¹⁾ [mm (inch)]	F [mm (inch)]	B [mm (inch)]	A [mm (inch)]	R [mm (inch)]	Weight [kg]	
Inch	DN	Inch	DN								
2	50	2	50	913 (35.94)	403 (15.87)	148 (5.83)	80 (3.15)	110 (4.33)	225 (8.86)	26	
		2½	65	1073 (42.24)						305 (12.01)	27
2½	65	2	50	1192 (46.93)	429 (16.89)	164 (6.64)	97 (3.82)	130 (5.12)	335 (13.19)	36	
		2½	65	1073 (42.24)						275 (10.83)	37
		3	80	1180 (46.46)						328 (12.91)	38
3	80	2½	65	1302 (51.26)	456 (17.95)	186 (7.32)	108 (4.25)	140 (5.51)	378 (14.88)	45	
		3	80	1180 (46.46)						296 (11.65)	44
		4	100	1448 (57.01)						430 (16.93)	46
4	100	3	80	1598 (62.91)	500 (19.69)	215 (8.46)	131 (5.16)	170 (6.69)	440 (17.32)	71	
		4	100	1448 (57.01)						365 (14.37)	69

¹⁾ For EEx add 54 mm

SITRANS F flowmeters

SITRANS F C

SITRANS F C MC2

Process Connections

- Flanges DIN/ASME
- Tri-Clamp DIN 32676
 - DN 15 to DN 50: Series 3
 - DN 65 to DN 100: Series 1
- Food Industry fittings DIN 11851

The max. allowable operating pressure is a function of the process connection type, the fluid temperature, the bolts and the gaskets.

Pressure Rating

- PN 16, PN 40, PN 100 (to DN 80 (3"))
 - Class 150, Class 300, Class 600 (to DN 80 (3"))

Housing as secondary containment

- max. 40 bar

Pressure Equipment Directive 97/23/EG

- Conformity evaluation category III, fluid group 1, gas, diamme 6

Corrosion resistance of measuring pipe material to measuring medium has to be considered.

Material strength for process connections

Process connection	Size		PS _{max.} bar (psi g)	TS _{max.} °C (°F)	TS _{min.} °C (°F)
	DN	Inch			
Thread acc. DIN 11851	15 ... 40	½ ... 1½	40 (580)	140 (284)	-40 (-40)
	50 ... 100	2 ... 4	25 (363)	140 (284)	-40 (-40)
Tri-Clamp acc. DIN 32676	15 ... 50	½ ... 2	16 (232)	120 (248)	-40 (-40)
	65 ... 100	2½ ... 4	10 (145)	120 (248)	-40 (-40)

Material Loads Curves for Flanged Flowmeters

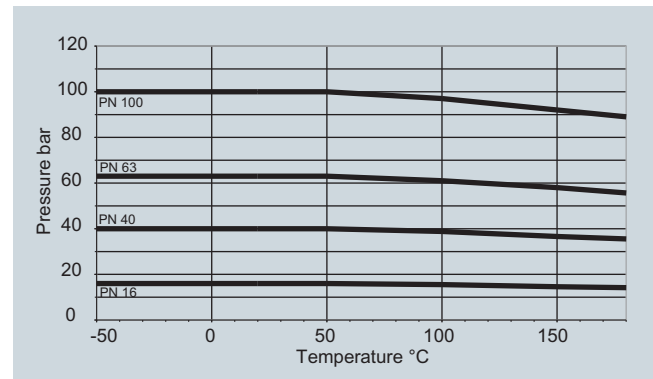

DIN-Flanges SS 1.4571/316Ti to DN 100 (4")

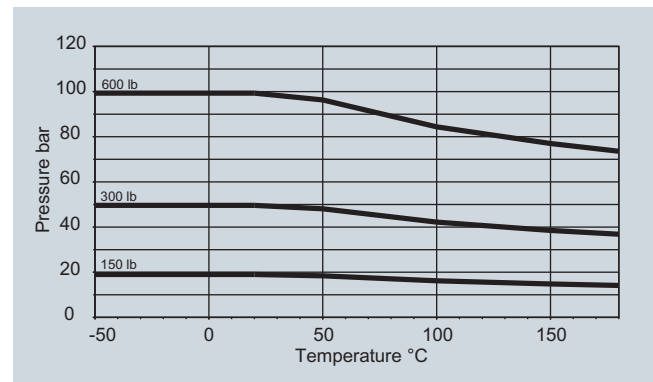

ASME-Flanges SS 1.4571/316Ti to DN 100 (4")

SITRANS F flowmeters

SITRANS F C

SITRANS F C MC2

Dimensional drawings

Remote Design, Food Industry Fitting, DIN 11851

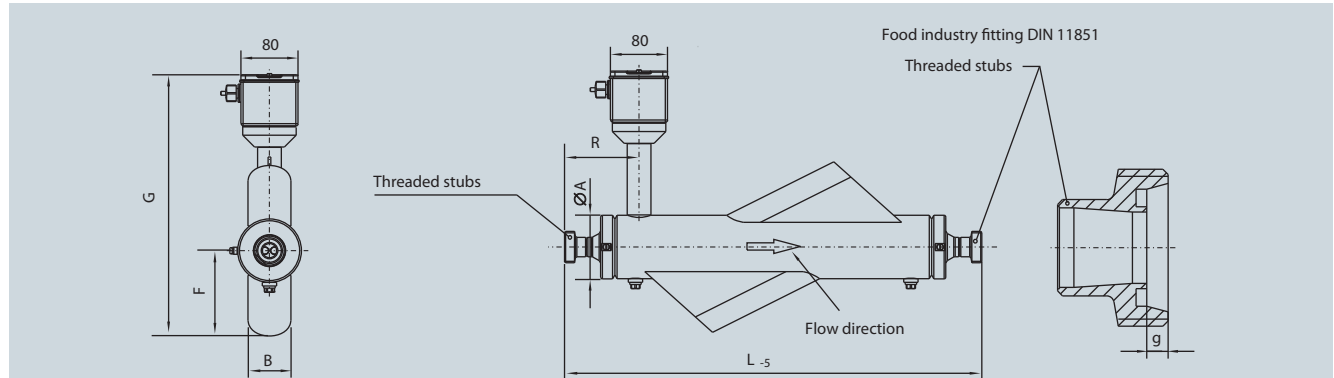

Dimensions in mm (inch)

DN (Size)		Process connections			L ₅	g	G	F	B	ØA	R	Weight
DN	inch	DN	inch		mm (inch)	mm (inch)	mm (inch)	mm (inch)	mm (inch)	mm (inch)	mm (inch)	kg
20	¾"	15	½"	Rd34 x 1/8	672 (26.46)	4 (0.16)	358 (14.94)	127 (5.00)	66 (2.60)	89 (3.50)	152 (5.98)	13
		20	¾"	Rd44 x 1/6	583 (22.95)	6 (0.24)					102 (4.02)	
		25	1"	Rd52 x 1/6	683 (26.89)	7 (0.28)					152 (5.98)	
25	1"	20	¾"	Rd44 x 1/6	743 (29.25)	6 (0.24)	358 (14.94)	127 (5.00)	66 (2.60)	89 (3.50)	162 (6.38)	14
		25	1"	Rd52 x 1/6	643 (25.31)	7 (0.28)					112 (4.11)	
		40	1½"	Rd65 x 1/6	786 (30.94)	7 (0.28)					185 (7.28)	



If this connection is supplied with an EHEDG-certified device, the device nominal sizes must correspond with the connection nominal sizes!

Remote Design, Food Industry Fitting, DIN 11851

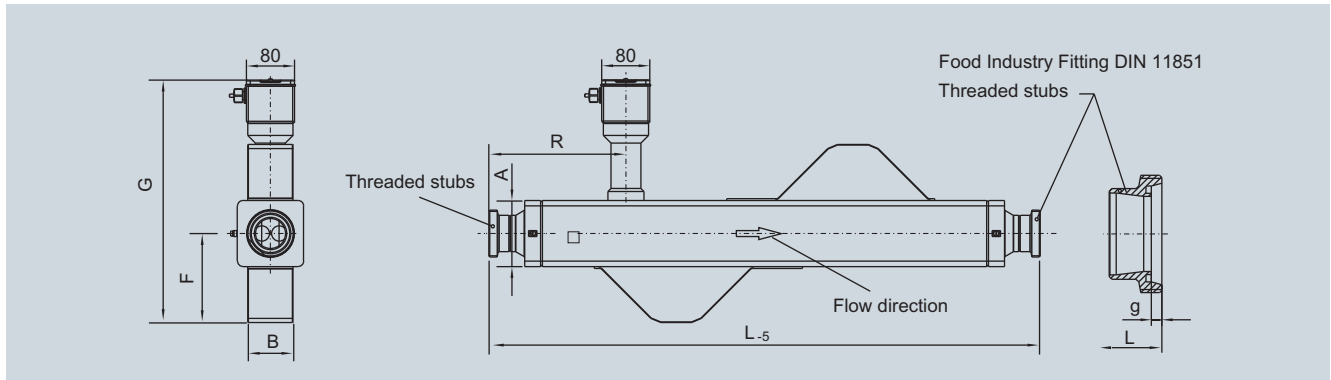

Dimensions in mm (inch)

DN (Size)		Process connections			L ₅	g	G	F	B	∅A	R	Weight
DN	inch	DN	inch		mm (inch)	mm (inch)	mm (inch)	mm (inch)	mm (inch)	mm (inch)	mm (inch)	kg
40	1½"	25	1	Rd52 x 1/6	864 (34.02)	7 (0.28)	374 (14.72)	129 (5.08)	64 (2.52)	90 (3.54)	218 (8.58)	16
		40	1½	Rd65 x 1/6	761 (29.96)	7 (0.28)					164 (6.46)	18
		50	2"	Rd78 x 1/6	918 (36.14)	7 (0.28)					241 (9.49)	19
50	2"	40	1½	Rd65 x 1/6	1025 (40.35)	7 (0.28)	403 (15.87)	148 (5.83)	80 (3.15)	110 (4.33)	233 (9.17)	28
		50	2"	Rd78 x 1/6	918 (36.14)	7 (0.28)					177 (6.97)	30
		65	2½	Rd95 x 1/6	1081 (42.56)	8 (0.31)					254 (10.00)	34
65	2½"	50	2"	Rd78 x 1/6	1197 (47.13)	7 (0.28)	429 (16.89)	164 (6.46)	97 (3.82)	130 (5.12)	291 (11.46)	40
		65	2½	Rd95 x 1/6	1081 (42.56)	8 (0.31)					227 (8.94)	44
		80	3"	Rd110 x 1/4	1200 (47.24)	8 (0.31)					281 (11.06)	47
80	3"	65	2½	Rd95 x 1/6	1310 (51.57)	8 (0.31)	456 (17.95)	186 (7.32)	108 (4.25)	140 (5.51)	319 (12.56)	54
		80	3"	Rd110 x 1/4	1200 (47.24)	8 (0.31)					258 (10.16)	56
		100	4"	Rd130 x 1/4	1463 (57.60)	10 (0.39)					381 (15.00)	60
100	4"	80	3"	Rd110 x 1/4	1618 (63.70)	8 (0.31)	500 (19.68)	215 (8.46)	131 (5.16)	170 (6.69)	401 (15.79)	82
		100	4"	Rd130 x 1/4	1463 (57.60)	10 (0.39)					314 (12.36)	86



If this connection is supplied with an EHEDG-certified device, the device nominal sizes must correspond with the connection nominal sizes!

SITRANS F flowmeters

SITRANS F C

SITRANS F C MC2

Remote Design, Tri-Clamp DIN 32676

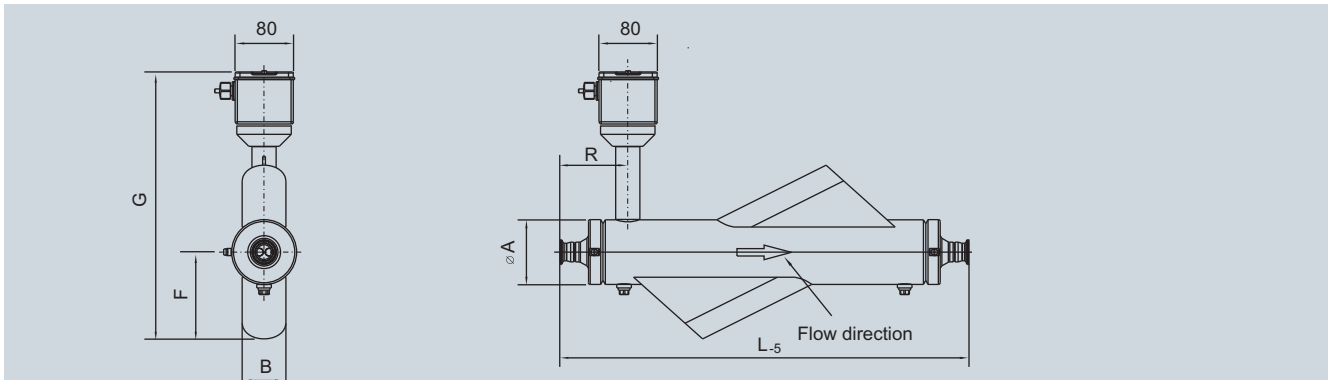

Dimensions in mm (inch)

DN (Size)		Process connections		L ₅	G	F	B	∅A	R	Weight
DN	inch	DN		mm (inch)	mm (inch)	mm (inch)	mm (inch)	mm (inch)	mm (inch)	kg
20	¾"	15 (½")	DIN 32676	656 (25.83)	358 (14.09)	127 (5.00)	66 (2.60)	89 (3.50)	140 (5.51)	12
		20 (¾")		561 (22.09)					92 (3.62)	
		25 (1")		661 (26.02)					142 (5.59)	
25	1"	20 (¾")	DIN 32676	721 (28.39)	358 (14.09)	127 (5.00)	66 (2.60)	89 (3.50)	152 (5.98)	13
		25 (1")		621 (24.45)					102 (4.02)	
		40 (1½")		773 (30.43)					180 (7.09)	



If this connection is supplied with an EHEDG-certified device, the device nominal sizes must correspond with the connection nominal sizes!

Remote Design, Tri-Clamp DIN 32676

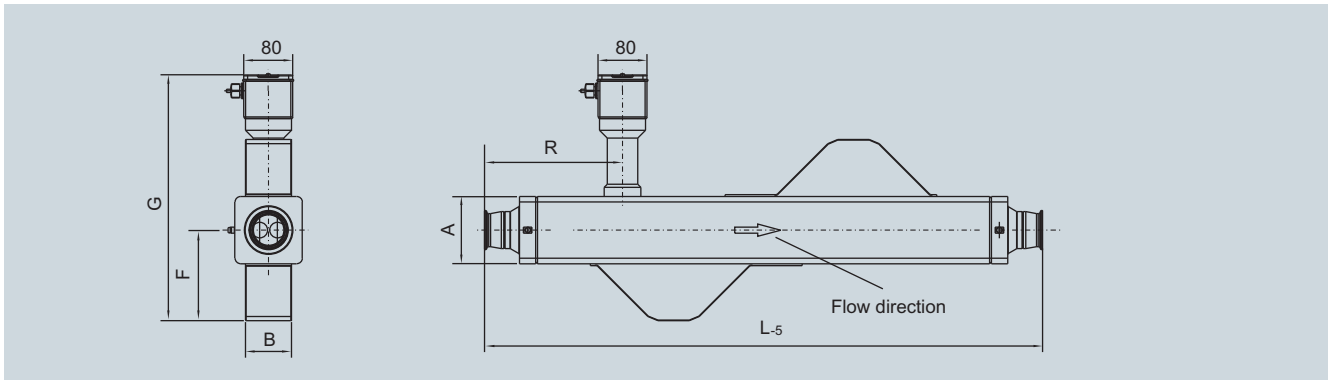

Dimensions in mm (inch)

DN (Size)		Process connections		L-5	G	F	B	ØA	R	Weight
DN	inch	DN	inch	mm (inch)	mm (inch)	mm (inch)	mm (inch)	mm (inch)	mm (inch)	kg
40	1½"	25	1	842 (33.15)	374 (14.72)	129 (5.08)	64 (2.52)	90 (3.54)	242 (9.53)	17
		40	1½	748 (29.45)					195 (7.68)	17
		50	2"	913 (35.94)					278 (10.94)	18
50	2"	40	1½	1012 (39.84)	403 (15.87)	148 (5.83)	80 (3.15)	110 (4.33)	275 (10.83)	27
		50	2"	913 (35.94)					225 (8.86)	26
		65	2½	1073 (42.24)					305 (12.01)	27
65	2½"	50	2"	1192 (46.93)	429 (16.89)	164 (6.46)	97 (3.82)	130 (5.12)	335 (13.19)	36
		65	2½	1073 (42.24)					275 (10.83)	37
		80	3"	1180 (46.46)					328 (12.91)	38
80	3"	65	2½	1302 (51.26)	456 (17.95)	186 (7.32)	108 (4.25)	140 (5.51)	378 (14.88)	45
		80	3"	1180 (46.46)					296 (11.65)	44
		100	4"	1448 (57.01)					430 (16.93)	46
100	4"	80	3"	1598 (62.91)	500 (19.68)	215 (8.46)	131 (5.16)	170 (6.69)	440 (17.32)	71
		100	4"	1448 (57.01)					365 (14.37)	69



If this connection is supplied with an EHEDG-certified device, the device nominal sizes must correspond with the connection nominal sizes!