

Maximizing SITRANS LR 300 Performance and Reliability

With Still Pipes, Sidepipes/Bypass Pipes, and Waveguides

Objective:	To achieve optimum level measurement performance and reliability in clean liquids, despite difficult level measurement application conditions such as foam, turbulence, low dielectric constant materials, and internal tank obstructions.	
Equipment:	<ul style="list-style-type: none">• SITRANS LR 300 Level Measurement System• Still pipe, Sidepipe/Bypass pipe, or Waveguide	
Contents	<ul style="list-style-type: none">• Overview• Application Do's and Don'ts• Pipe Construction Detail• Handling Low Dielectric Constant Materials	<ul style="list-style-type: none">• SITRANS LR 300 with WaveGuide Antenna• Propagation Rate Adjustment• Performance Benefits

Overview

As a general rule, using a still pipe, side pipe, or waveguide improves SITRANS LR 300 performance in any application measuring "clean" liquid levels.

A still pipe is an existing or newly fabricated pipe that runs inside the vessel from top to near bottom. A sidepipe or bypass pipe runs outside the vessel but is connected at top and bottom (as shown in Fig.1). A waveguide is a pipe that is an optional integral part of the SITRANS LR 300.

When microwaves propagate within a conductive pipe, the natural beam spread is eliminated, focusing more energy to the material level and resulting in stronger echoes.

At the same time, the pipe itself stills the material surface, producing an ideal reflective surface and eliminating many other influences that can otherwise reduce echo confidence and level measurement reliability.

Therefore, when monitoring clean free flowing liquids, mount the SITRANS LR 300 to an existing tank still pipe or sidepipe despite any other potential mounting location. If neither is available, consider using a waveguide antenna.

The balance of this application guide provides specific details for the proper application of the SITRANS LR 300 to these pipes and the effective use of waveguides.

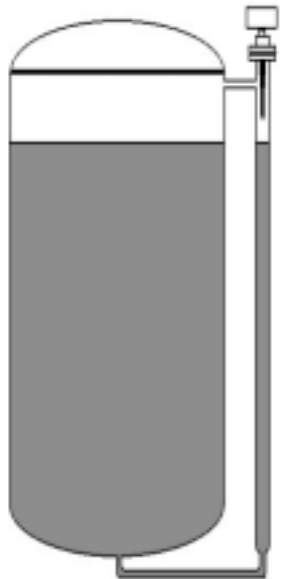

Fig. 1 SITRANS LR 300 mounted on tank equipped with side pipe.

MILLTRONICS

APPLICATION GUIDE

Application Do's and Don'ts

These lists provide brief descriptions of when and how you should and shouldn't use still pipes, side pipes and waveguides. (For additional information, refer to the detail that follows).

Do's

Do use pipes or waveguides to overcome the following application problems for clean liquids:

- a) Low Dielectric Constant – the focused microwave energy overcomes the higher signal absorption.
- b) Vortex – the surface measured is isolated from the vortex producing a superior reflective surface.
- c) Foam – the surface measured is isolated from the foam generated during filling or agitation.
- d) Internal Obstructions – the reflections from off-axis obstructions are eliminated.
- e) Multiple Echoes – the off-axis reflections from a centre-mounted unit on a domed vessel roof are eliminated.

Do use continuous pipe or adhere to pipe construction recommendations.

Do ensure the pipe is vented so that the material rise and fall is not impeded.

Do adjust the Propagation Rate (P655) to suit the pipe diameter used.

Do use the First Echo algorithm (P820 = 12) to avoid potential multiple echo detection

Do use a deflection plate if a low dielectric constant material must be measured within 40 cm (16") of the tank bottom.

Do use the largest diameter pipe practical if some material build-up may occur inside the pipe.

Don'ts

Don't use still pipes or waveguides for materials that may build up within the pipe.

Don't attempt to use non-conductive pipes. (They allow microwave energy to pass right through).

Don't use a waveguide if excessive turbulence exists. (To avoid potential damage, use a heavy still pipe instead).

Don't attempt to use pipes or waveguides with an internal diameter less than 50 mm (2").

Don't be surprised by the significantly higher signal strength and echo confidence readings.

APPLICATION GUIDE

Pipe Construction Detail

Still pipes and sidepipes must be constructed of a conductive material, typically carbon or stainless steel. The pipe must be open at the bottom to allow fluid to enter, and vented at the top (as near the SITRANS LR 300 as possible), to allow the fluid to rise and fall unimpeded.

Ideally, these pipes will be continuous over their entire length without any internal seams, threads, welds, or burrs, that may reflect microwave energy and cause a false echo.

If pipe lengths must be joined, follow these recommendations

1. Make as few joins as possible.
2. Use only machined connections that maintain +/- 0.010" pipe I.D. tolerance.
3. Remove any internal lip or burr. **Do not chamfer the mating surfaces!**
4. Slide a metal collar over the joint.
5. Weld the collar top and bottom.

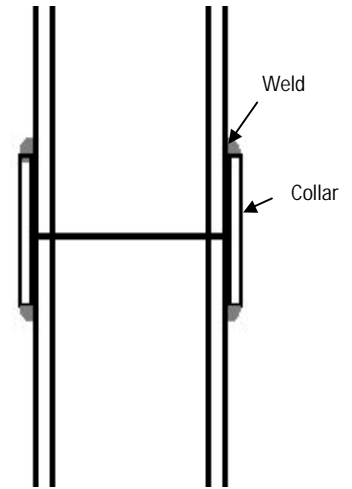

Fig. 2 Recommended pipe seam construction techniques.

Low Dielectric Constant Materials

When measuring materials with a low dielectric constant, to avoid detecting the pipe end or a flat tank bottom, always use the First echo algorithm ($P820 = 12$) and a pipe end deflector.

Microwaves propagate differently within an enclosed space than they do in free space. When microwave energy is transmitted down a narrow pipe that abruptly terminates into an opening, some microwave energy may be reflected from that point. These reflections can normally be avoided by ensuring the pipe extends into the tank beyond the lowest level monitored, and always using the First echo algorithm.

To select the First Echo Algorithm, set $P820 = 12$.

When measuring materials with a very low dielectric constant ($DK = 3$ or less), a pipe end deflector may be used to ensure the tank bottom isn't detected. Without a pipe end deflector, at some low tank level (typically 30 to 45 cm), sufficient microwave energy can pass through the material and be reflected off the tank bottom, to produce a much larger echo than from the material surface. This may cause the reading to suddenly jump to the empty level, even though there is still material in the tank.

By using a pipe end deflector, any microwave energy that is not reflected from the material surface is deflected into the tank, scattered, and absorbed.

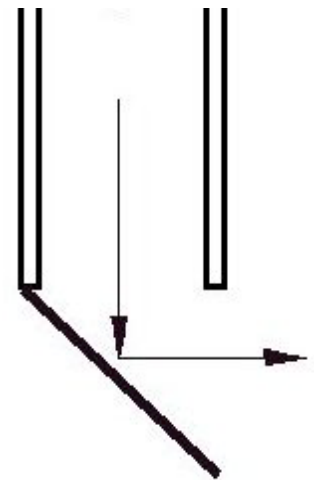

Fig. 3 Pipe end deflector for low dielectric constant materials.

APPLICATION GUIDE

SITRANS LR 300 with Waveguide Antenna

For smaller vessels that are not already equipped with a still pipe or side pipe, use a SITRANS LR 300 integral waveguide to achieve the same performance benefits.

A waveguide may be used with any process flange sizes 3" ANSI or larger. The waveguide section is available in custom lengths to suit the tank height up to 5m (16.5'). (For higher vessels a still pipe or side pipe should be used).

A waveguide should only be used in this manner if the material viscosity and turbulence is minimal. (Otherwise the unit could be damaged on vessel filling, emptying, or agitation).



Fig. 4 SITRANS LR 300 with integral waveguide antenna.

Propagation Rate Adjustment

Microwaves propagate in free space at the speed of light, regardless of the atmosphere present (or complete lack thereof). The SITRANS LR 300 relies on this velocity to calculate the distance measured based on time-of-flight principles.

Inside a pipe, however, the relationship between the wavelength (frequency) and the pipe diameter affects the microwave propagation velocity. To achieve optimum accuracy, this velocity deviation may be programmed via Propagation Rate (P655).

As factory preset, P655 = 1 (speed of light). Set P655 for the corresponding pipe or waveguide diameter per the following chart.

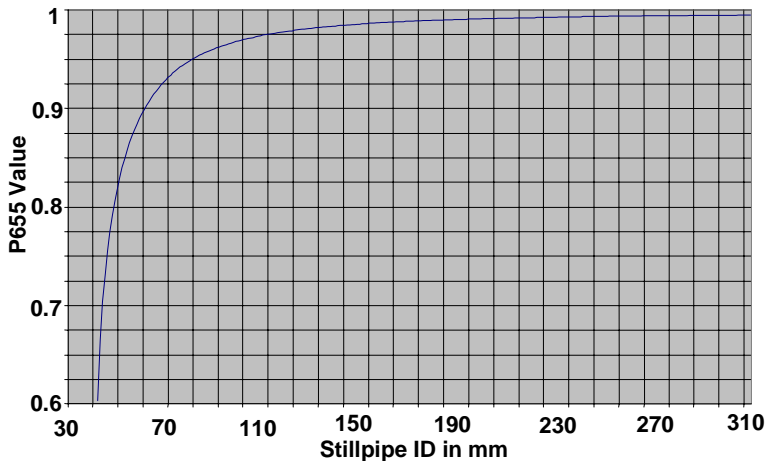

Fig. 5 Stillpipe I.D. vs Propagation Factor

The minimum allowable pipe or waveguide internal diameter is 50 mm (2").

Pipe	P655 Value
50 mm (2")	0.827
80 mm (3")	0.915
100 mm (4")	0.955
150 mm (6")	0.980
200 mm (8")	0.990

Fig. 6 Propagation Rate adjustment for common pipe internal diameters.

APPLICATION GUIDE

Performance Benefits

Compared to free space, the signal quality derived using a conductive still pipe is far superior. As all of the microwave energy is contained within the pipe, energy losses due to beam spreading are avoided, resulting in larger echoes.

Similarly, reflections from off-axis internal tank obstructions are eliminated, reducing the signal noise floor and false echoes.

For these reasons, improved measurement reliability and increased system accuracy are achievable. Notice the extremely high signal amplitude in the following echo profile, typical of a still pipe application.

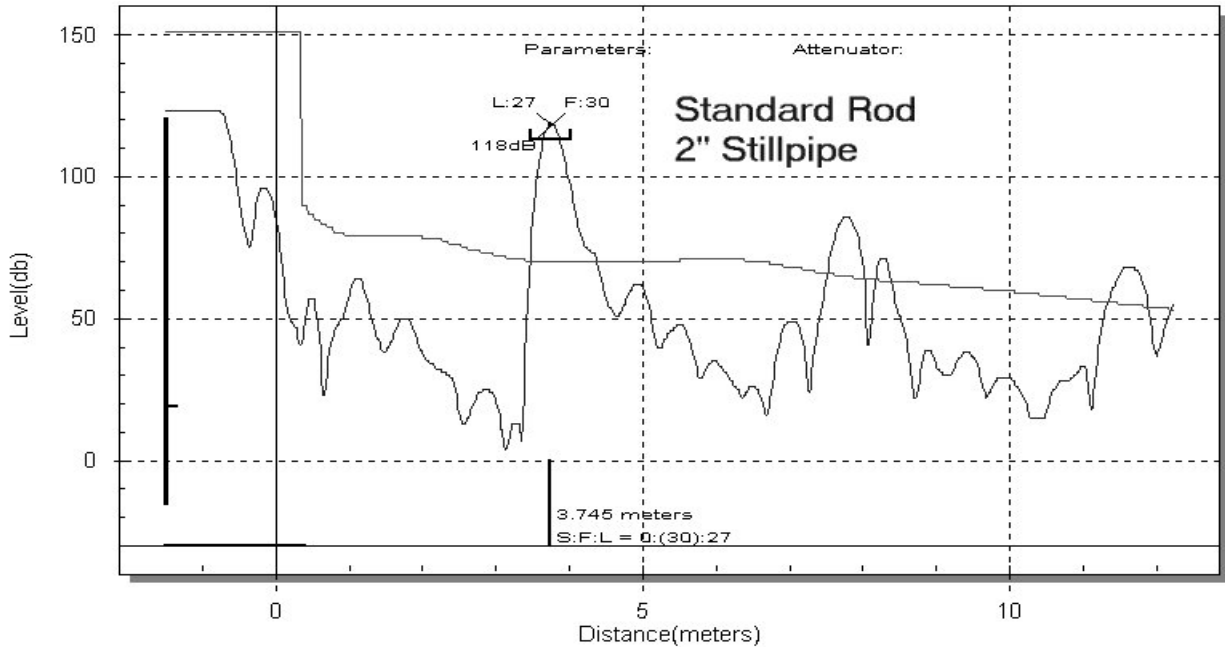

Fig. 7 Typical SITRANS LR 300 echo profile using a standard rod antenna in a 2" (50mm) still pipe.