

DELTA i-system	Pushbutton wave shutter	UP 211	5WG3 211-2HB_1
DELTA profil	Pushbutton wave shutter	UP 211	5WG3 211-2AB_1
DELTA style	Pushbutton wave shutter	UP 211	5WG3 211-2GB_1

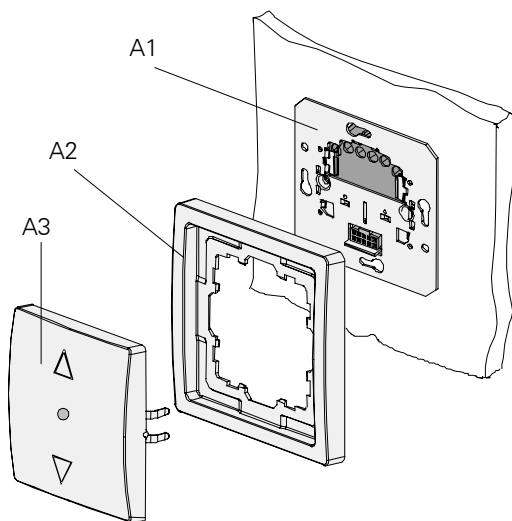

Product	DELTA i-system	DELTA profil	DELTA style
Pushbutton wave shutter	5WG3 211-2HB11 titanium white	5WG3 211-2AB01 pearl grey	5WG3 211-2GB11 titanium white
	5WG3 211-2HB21 carbon metallic	5WG3 211-2AB11 titanium white	5WG3 211-2GB21 basalt black
	5WG3 211-2HB31 aluminum metallic	5WG3 211-2AB21 anthracite	5WG3 211-2GB41 platinum metallic
		5WG3 211-2AB71 silver	
Frame	must be separately ordered from the DELTA product range		
	---	cut-out frames	---



- A1 Shutter control insert sys
- A2 Frame
- A3 Pushbutton wave shutter UP 211 \*)
- A4 LED \*)

\*) included with supply

Diagram A: Mounting the Pushbutton wave shutter UP 211

## Product and Applications Description

The pushbutton wave shutter UP 211 is a single radio control pushbutton used both as a transmitter and a receiver for controlling shutters. The available colours match the DELTA switch ranges i-system DELTA profil and DELTA style.

The pushbutton is clipped onto the shutter control insert together with the relevant frame of the switch ranges (to be ordered separately).

An additional function is to operate the insert located beneath the pushbutton as well as inserts connected via radio control with a 24 hour automatic mode.

DELTA i-system	Pushbutton wave shutter	UP 211	5WG3 211-2HB_1
DELTA profil	Pushbutton wave shutter	UP 211	5WG3 211-2AB_1
DELTA style	Pushbutton wave shutter	UP 211	5WG3 211-2GB_1

The commissioning of the pushbutton wave shutter is carried out without any additional means via pushbutton actions (Easy mode Push Button: EP).

There are two different operation modes which can be used by the pushbutton wave shutter:

#### Normal function

- Operation of the insert located beneath the pushbutton
- Remote operation of the insert located beneath the pushbutton via other radio control pushbuttons or radio control transmitters
- Remote operation of other inserts connected via radio control
- Setting/activating/deactivating the 24 hour automatic mode

#### Special function

- Establishing connections with other radio control components
- Deleting connections with other radio control components
- Deleting switching intervals of the 24 hour automatic mode

## Operation

The operation of the pushbutton wave shutter can be carried out at the TOP, BOTTOM or in the CENTRE (i.e. TOP and BOTTOM simultaneously). The commands UP/DOWN and STEP (i.e. STOP or OPEN/CLOSE the louvres gradually) and a saving function for the 24 hour automatic mode are available.

#### **STEP command** (Actions shorter than 0.4s):

TOP        STOP/louvres OPEN  
 BOTTOM    STOP/louvres CLOSED

#### **UP/DOWN command** (Actions between 0.4s and 3s):

TOP        UP command  
 BOTTOM    DOWN command

#### **Set / activate / deactivate 24 hour automatic mode:**

##### **1. Select 24 hour automatic mode**

Action: Press the pushbutton rocker in the CENTRE for between 3 and 10 seconds.

Display: The LED of the pushbutton flashes briefly after 3 seconds; the pushbutton rocker can be released.

If step 2 is not carried out, the 24 hour automatic mode is activated or deactivated.

The storing of the switching times for upward and downward movement must be carried out within 3 seconds.

#### **2. Storing periods for upward and downward movement**

TOP        Saves period for upward movement

or

BOTTOM    Saves period for downward movement

The switching time which has been set in the automatic operation mode is carried out again every 24 hours, once it has been saved and activated. If e.g. a period for downward movement is saved at 7 o'clock in the evening and a period for upward movement is saved at 7 o'clock in the morning, these UP and DOWN commands are repeated each day at the same time.

The automatic movement commands are also transmitted to further shutters that are linked via radio control.

The 24 hour automatic mode is activated immediately if a period for UP or DOWN movement has been saved successfully.

The LED located in the centre of the pushbutton is permanently lit to indicate that the 24 hour automatic mode has been activated.

**Note:** Depending on the device tolerances and temperature fluctuations, the stored switching times for upward and downward movement can be adjusted every day by several minutes.

## Technical Specifications

#### **Frequency band**

- 868 MHz (transmission is not susceptible to interference; frequency band reserved for system and security applications)

#### **Range of radio control**

- approx. 100 m (applying to free field applications)

#### **Power supply**

- via the 230V physical external interface (230V-PEI) of the shutter control inserts sys

DELTA i-system	Pushbutton wave shutter	UP 211	5WG3 211-2HB_1
DELTA profil	Pushbutton wave shutter	UP 211	5WG3 211-2AB_1
DELTA style	Pushbutton wave shutter	UP 211	5WG3 211-2GB_1

### Connections

- 10 pin bar (230V-PEI) for connection to the shutter control insert sys

### Mechanical specifications

- Housing: plastic
- Dimensions (L x W x D):
  - DELTA i-system 55x55x24mm (including spring)
  - DELTA profil 65x65x25mm (including spring)
  - DELTA style 68x68x27mm (including spring)
- Weight: approx. 35g
- Fire load: approx. 950kJ
- Mounting: placed on the shutter control inserts sys

### Electrical safety

- Pollution degree (according to IEC 60664-1): 2
- Protection (according to EN 60529): IP 20
- Overvoltage category (according to IEC 60664-1): III
- Device complies with EN 60669-2-1 and IEC 60664-1

### Electromagnetic compatibility

complies with EN 60669-2-1, EN 301489, EN 300220

### Environmental specifications

- Climatic conditions: EN 50090-2-2
- Ambient operating temperature: - 5 ... + 45°C
- Storage temperature: - 25 ... + 70°C
- Relative humidity (non-condensing): 5% to 93%

### Markings

- KNX / EIB



### CE norm

complies with the EMC regulations (residential buildings), low voltage regulations and R&TTE regulations

### Declaration of conformity

SIEMENS AG declares herewith that the pushbutton wave shutter UP 211 comply with the basic requirements and other relevant regulations of Directive 1999/5/EG.

The CE declaration can be inspected at:

SIEMENS AG  
Siemensstraße 10  
93055 Regensburg

### Installation Instructions

#### Caution:

- The device may be used for interior installations and in dry rooms only.
- The installation of the device into metal walls has to be avoided since through this the range of radio control is reduced considerably.
- Occasionally the transmission range may be influenced by structural conditions (e.g. reinforced concrete) or electric / electronic sources of interference.
- A minimum distance of 0.5 m must be maintained between the transmitter and the relevant receivers.
- Though the radio transmission is carried out in the safe 868 MHz range, disruptions to the radio transmission cannot be excluded.
- The radio transmission is not suitable for security applications.



#### DANGER

- The device must be mounted and commissioned by an authorized electrician.
- The device may be mounted to switch and socket combination box mounts if VDE-certified devices are used exclusively.
- The device must not be opened.
- For planning and construction of electric installations, the relevant guidelines, regulations and standards of the respective country are to be considered.

### Mounting

The pushbutton wave shutter is clipped onto the shutter control insert sys together with its frame. The electrical connection between the pushbutton and the shutter control insert is thus established via the 230V-PEI.

DELTA i-system	Pushbutton wave shutter	UP 211	5WG3 211-2HB_1
DELTA profil	Pushbutton wave shutter	UP 211	5WG3 211-2AB_1
DELTA style	Pushbutton wave shutter	UP 211	5WG3 211-2GB_1

Mounting of the Pushbutton wave shutter UP 211:

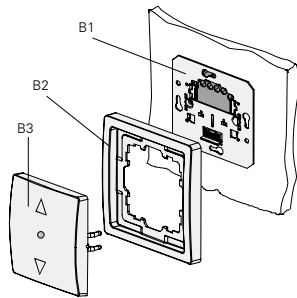

Diagram B

- B1 Shutter control insert sys
- B2 Frame
- B3 Pushbutton wave shutter UP 211

- 1) The shutter control insert sys is connected and mounted within the flush-type box (see installation instructions for shutter control insert sys).
- 2) Place the pushbutton wave shutter together with its frame onto the shutter control insert sys.

Dismantling:

Remove the pushbutton wave shutter manually together with its frame (Diagram C).

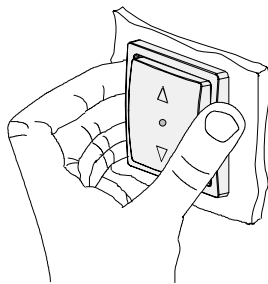

Diagram C

**Caution:** Cut-out frames have to be used to integrate the pushbutton wave shutter into the DELTA profil range!

**Dimension Diagram**

Dimensions in mm

	A	B	C	D
DELTA i-system	55	55	24	13
DELTA profil	65	65	25	14
DELTA style	68	68	27	16, 5

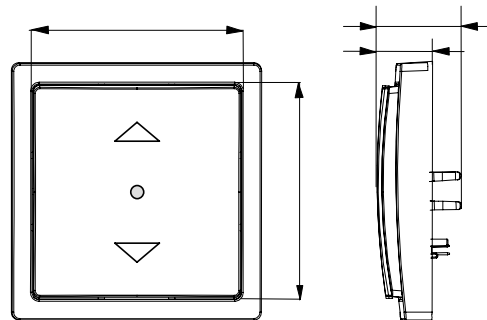

**Commissioning**

The function of the insert located beneath the pushbutton is ensured without further commissioning once the pushbutton has been placed on it.

If further shutter control inserts sys are to be operated via the remote control mode, radio control connections must first be established between each insert. Shutter control inserts sys which have to be connected must also be equipped with a pushbutton wave shutter.

The connection of the pushbutton wave shutter with other radio components is carried out by pressing the pushbutton. To do so, the special function must be set for the two devices which have to be connected with each other. The operating state of the pushbutton and the successful connection are displayed by the LED located in the centre of the pushbutton.

**Connection via radio control:**

Connecting the pushbutton wave shutter I with a shutter control insert sys II via radio control.

DELTA i-system	Pushbutton wave shutter	UP 211	5WG3 211-2HB_1
DELTA profil	Pushbutton wave shutter	UP 211	5WG3 211-2AB_1
DELTA style	Pushbutton wave shutter	UP 211	5WG3 211-2GB_1

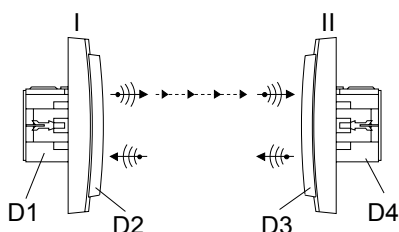

Diagram D

- D1 Shutter control insert sys I
- D2 Pushbutton wave shutter I
- D3 Pushbutton wave shutter II
- D4 Shutter control insert sys II

### 1. Pushbutton wave shutter II: Switch to the special function (D3).

Action: Press the pushbutton rocker II in the CENTRE for at least 10 seconds.

Display: The LED of the pushbutton begins to flash slowly (approx. once per second) after 10 seconds (toggling to the special function).

### 2. Pushbutton wave shutter I: Switch to the special function (D2).

Action: Press the pushbutton rocker I in the CENTRE for at least 10 seconds.

Display: The LED of the pushbutton begins to flash slowly (approx. once per second) after 10 seconds (toggling to the special function).

### 3. Pushbutton wave shutter I: Transmit a linking telegram (D2).

Action: Brief operation (up to 0.4 sec.) of the pushbutton rocker I at the TOP, CENTRE or BOTTOM.

Display: The LED of pushbutton wave shutter I flashes rapidly (3 times per second) for approx. 3 seconds if the connection has been established successfully. The LED is then extinguished and the pushbutton exits the special function. The LED of the pushbutton wave shutter II also flashes and is extinguished. The pushbutton then exits the special function.

**Note:** There is only a limited period available for the connection as the pushbuttons wave shutter exit the special function after 2 minutes.

The connection of pushbutton wave shutter I with shutter control insert II is complete.

When pushbutton wave shutter I (D2) is pressed, the shutter control insert sys II (D4) is also operated via radio control.

If the connection has failed (e.g. if the distance is too great), the two pushbuttons wave shutter exit the special function after max. 2 minutes, without confirming the success of the connection by flashing rapidly.

This procedure must be repeated if pushbutton wave shutter I is to be connected with other shutter control inserts sys.

An unlimited number of shutter control inserts sys can be operated via remote control by the pushbutton wave shutter (Diagram E).

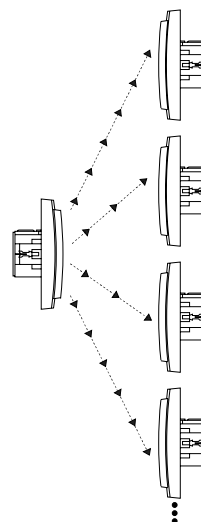

Diagram E

DELTA i-system	Pushbutton wave shutter	UP 211	5WG3 211-2HB_1
DELTA profil	Pushbutton wave shutter	UP 211	5WG3 211-2AB_1
DELTA style	Pushbutton wave shutter	UP 211	5WG3 211-2GB_1

A shutter control insert sys equipped with a pushbutton wave shutter can be operated via remote control by up to 10 radio control pushbuttons (Diagram F).

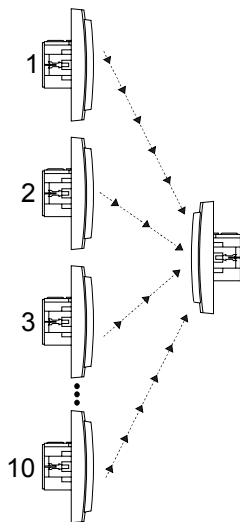

Diagram F

If you wish shutter control insert I (G1 in Diagram G) to be operated via remote control by pushbutton wave shutter II (G3), the two pushbuttons wave shutter I and II must be switched to the special function again. However, the linking telegram has to be triggered at pushbutton wave shutter II.

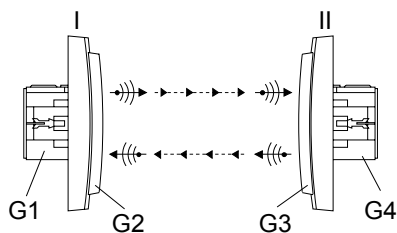

Diagram G

- G1 Shutter control insert sys I
- G2 Pushbutton wave shutter I
- G3 Pushbutton wave shutter II
- G4 Shutter control insert sys II

**Procedure for deleting a connection:**

Single connections can be deleted by assigning the new correlation.

Deletion of the connection between the pushbutton wave shutter in combination I and the shutter control insert sys in combination II (Diagram D).

1. Pushbutton wave shutter II: Switch to the special function
2. Pushbutton wave shutter I: Switch to the special function
3. Pushbutton wave shutter I: Trigger the linking telegram

The connection between pushbutton wave shutter I and shutter control insert II is thereby deleted.

**Deleting all connections and resetting the supplied state:**

**1. Switch the pushbutton wave shutter to the special function.**

Action: Press the pushbutton rocker in the CENTRE for at least 10 seconds.

Display: The LED of the pushbutton begins to flash slowly (approx. once per second) after 10 seconds (toggling to the special function).

**2. Reset the device.**

Action: Press the pushbutton rocker again in the CENTRE for at least 10 seconds.

Display: The LED of the pushbutton flashes rapidly (3 times per second) for approx. 3 seconds. The LED is then extinguished and the pushbutton exits the special function.

All connections are deleted. The device is restored to its initial state.

Connections of this pushbutton wave shutter to other inserts are retained and must likewise be deleted.

DELTA i-system	Pushbutton wave shutter	UP 211	5WG3 211-2HB_1
DELTA profil	Pushbutton wave shutter	UP 211	5WG3 211-2AB_1
DELTA style	Pushbutton wave shutter	UP 211	5WG3 211-2GB_1

#### Delete automatic 24 hour switching intervals:

##### 1. Switch the pushbutton wave shutter to the special function.

Action: Press the pushbutton rocker in the CENTRE for at least 10 seconds.

Display: The LED of the pushbutton begins to flash slowly (approx. once per second) after 10 seconds.

##### 2. Delete the switching times.

Action: Long operation (between 3 and 10 seconds) of the pushbutton rocker at the TOP to delete the period for upward movement or at the BOTTOM to delete the period for downward movement.

The set period for upward or downward movement is deleted. Once these time settings have been successfully deleted, the 24 hour automatic mode is disabled. The LED located in the centre of the pushbutton is extinguished. The device is in the normal mode.

#### Exiting the special function:

If the pushbutton wave shutter is operated in the special function mode, this state is terminated by the following actions and switched back to normal mode.

1. Transmission of a linking telegram.
2. Receipt of a linking telegram.
3. Deletion of an automatic 24 hour switching interval (long operation (between 3 and 10 seconds) of the pushbutton rocker at the TOP or BOTTOM).
4. Time out after 2 minutes (no pushbutton actions are carried out and no linking telegrams are received for a period of two minutes).

#### General Notes

- The operating instructions must be handed over to the client.
- Any faulty device should be returned to the local Siemens office.
- If you have further questions concerning the product please contact our technical support:

 +49 (180) 5050-222

 +49 (180) 5050-223

 [www.siemens.com/automation/support-request](http://www.siemens.com/automation/support-request)