

DELTA i-system	Pushbutton wave	UP 210	5WG3 210-2HB_1
DELTA profil	Pushbutton wave	UP 210	5WG3 210-2AB_1
DELTA style	Pushbutton wave	UP 210	5WG3 210-2GB_1

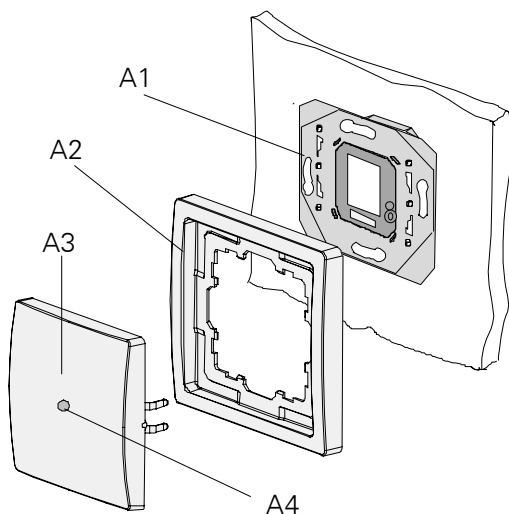

Product	DELTA i-system	DELTA profil	DELTA style
Pushbutton wave	5WG3 210-2HB11 titanium white	5WG3 210-2AB01 pearl grey	5WG3 210-2GB11 titanium white
	5WG3 210-2HB21 carbon metallic	5WG3 210-2AB11 titanium white	5WG3 210-2GB21 basalt black
	5WG3 210-2HB31 aluminum metallic	5WG3 210-2AB21 anthracite	5WG3 210-2GB41 platinum metallic
		5WG3 210-2AB71 silver	
Frame	must be separately ordered from the DELTA product range		
	---	cut-out frames	---



- A1 Switch or dimmer insert sys
- A2 Frame
- A3 Pushbutton wave UP 210 \*)
- A4 LED \*)

\*) included with supply

Diagram A: Mounting the Pushbutton wave UP 210

## Product and Applications Description

The pushbutton wave UP 210 is a single radio control pushbutton used both as a transmitter and a receiver for lighting control.

The available colours match the DELTA switch ranges i-system, DELTA profil and DELTA style.

The pushbutton is clipped onto the switch or dimmer insert sys together with the relevant frame of the switch ranges (to be ordered separately).

An additional function besides the wireless remote control is the operation of the insert located beneath the pushbutton as a time switch with an adjustable overshoot time of 1-60 minutes.

DELTA i-system	Pushbutton wave	UP 210	5WG3 210-2HB_1
DELTA profil	Pushbutton wave	UP 210	5WG3 210-2AB_1
DELTA style	Pushbutton wave	UP 210	5WG3 210-2GB_1

The commissioning of the pushbutton wave is carried out without any additional means via pushbutton actions (Easy mode Push Button: EP).

There are two different operation modes which can be used by the pushbutton wave:

#### Normal function

- Operation of the insert located beneath the pushbutton
- Remote operation of the insert located beneath the pushbutton via other radio control pushbuttons or radio control transmitters
- Remote operation of other inserts connected via radio control
- storing a memory brightness value

#### Special function

- Establishing connections with other radio control components
- Deleting connections with other radio control components
- Activating, setting and disabling the time switch function

## Operation

The operation of the pushbutton wave can be carried out at the TOP, BOTTOM or in the CENTRE (i.e. TOP and BOTTOM simultaneously). The exact functionality of the pushbutton wave depends on the inserts sys used: switch (switching only) or dimmer (switching, dimming and memory).

#### **Switching** (Actions shorter than 0.4s):

TOP: TOGGLE (i.e. OFF or ON with saved memory value)  
 BOTTOM: TOGGLE  
 CENTRE: TOGGLE

**Note:** If the time switch function is active the overshoot time is restarted with every further pushbutton activity.

#### **Dimming** (Actions between 0.4s and 3s):

TOP: Dimming BRIGHTER up to max. light intensity  
 BOTTOM: Dimming DARKER down to min. light intensity

#### **Memory function** (Actions between 3s and 10s):

CENTRE: Stores the current brightness value as a memory value. The LED of the pushbutton wave flashes briefly after 3 seconds. The storing of the brightness value is confirmed by the dimmer insert sys by switching the connected loads OFF briefly and then ON again.

## Technical Specifications

#### **Frequency band**

- 868 MHz (transmission is not susceptible to interference; frequency band reserved for system and security applications)

#### **Range of radio control**

- approx. 100 m (applying to free field applications)

#### **Power supply**

- via the 230V physical external interface (230V-PEI) of the switch or dimmer inserts sys

#### **Connections**

- 10 pin bar (230V-PEI) for connection to the switch or dimmer inserts sys

#### **Mechanical specifications**

- Housing: plastic
- Dimensions (L x W x D):  
 DELTA i-system 55x55x24mm (including spring)  
 DELTA profil 65x65x25mm (including spring)  
 DELTA style 68x68x27mm (including spring)
- Weight: approx. 35g
- Fire load: approx. 950kJ
- Mounting: placed on the switch or dimmer inserts sys

#### **Electrical safety**

- Pollution degree (according to IEC 60664-1): 2
- Protection (according to EN 60529): IP 20
- Overvoltage category (according to IEC 60664-1): III
- Device complies with EN 60669-2-1 and IEC 60664-1

#### **Electromagnetic compatibility**

- complies with EN 60669-2-1, EN 301489, EN 300220

DELTA i-system	Pushbutton wave	UP 210	5WG3 210-2HB_1
DELTA profil	Pushbutton wave	UP 210	5WG3 210-2AB_1
DELTA style	Pushbutton wave	UP 210	5WG3 210-2GB_1

### Environmental specifications

- Climatic conditions: EN 50090-2-2
- Ambient operating temperature: - 5 ... + 45°C
- Storage temperature: - 25 ... + 70°C
- Relative humidity (non-condensing): 5% to 93%

### Markings

- KNX / EIB



### CE norm

complies with the EMC regulations (residential buildings), low voltage regulations and R&TTE regulations

### Declaration of conformity

SIEMENS AG declares herewith that the pushbutton wave UP 210 comply with the basic requirements and other relevant regulations of Directive 1999/5/EG.

The CE declaration can be inspected at:  
SIEMENS AG  
Siemensstraße 10  
93055 Regensburg

### Installation Instructions

#### Caution:

- The device may be used for interior installations and in dry rooms only.
- The installation of the device into metal walls has to be avoided since through this the range of radio control is reduced considerably.
- Occasionally the transmission range may be influenced by structural conditions (e.g. reinforced concrete) or electric / electronic sources of interference.
- A minimum distance of 0.5 m must be maintained between the transmitter and the relevant receivers.
- Though the radio transmission is carried out in the safe 868 MHz range, disruptions to the radio transmission cannot be excluded.
- The radio transmission is not suitable for security applications.

### DANGER

- The device must be mounted and commissioned by an authorized electrician.
- The device may be mounted to switch and socket combination box mounts if VDE-certified devices are used exclusively.
- The device must not be opened.
- For planning and construction of electric installations, the relevant guidelines, regulations and standards of the respective country are to be considered.

### Mounting

The pushbutton wave is clipped onto the switch or dimmer insert sys together with its frame. The electrical connection between the pushbutton and the insert is thus established via the 230V-PEI.

#### Mounting of the pushbutton wave UP 210:

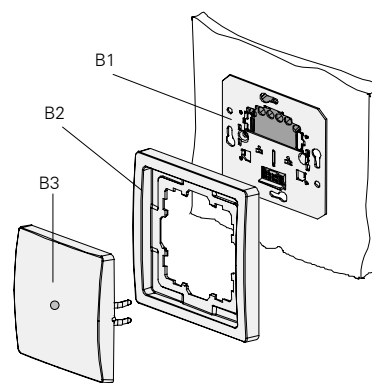

Diagram B

- B1 Switch insert sys or dimmer insert sys
- B2 Frame
- B3 Pushbutton wave UP 210

- 1) The switch or dimmer insert sys is connected and mounted within the flush-type box (see installation instructions for switch or dimmer insert sys).
- 2) Place the pushbutton wave together with its frame onto the switch or dimmer insert sys.

DELTA i-system	Pushbutton wave	UP 210	5WG3 210-2HB_1
DELTA profil	Pushbutton wave	UP 210	5WG3 210-2AB_1
DELTA style	Pushbutton wave	UP 210	5WG3 210-2GB_1

Dismantling:

Remove the pushbutton wave manually together with its frame (Diagram C).

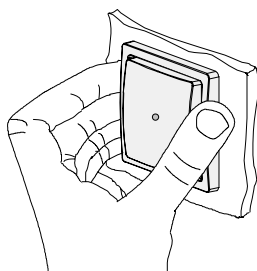

Diagram C

**Caution:** Cut-out frames have to be used to integrate the pushbutton wave into the DELTA profil range!

**Dimension Diagram**

Dimensions in mm

	A	B	C	D
DELTA i-system	55	55	24	13
DELTA profil	65	65	25	14
DELTA style	68	68	27	16, 5

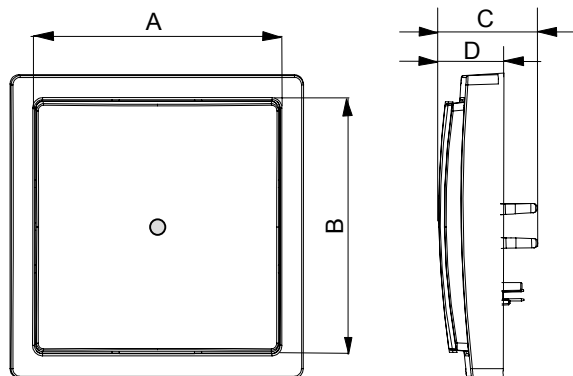

**Commissioning**

The function of the insert located beneath the pushbutton is ensured without further commissioning once the pushbutton has been placed on it.

If further switch or dimmer inserts sys are to be operated remotely, they must first be linked via radio control. Any switch or dimmer inserts sys which have to be connected must also be equipped with a pushbutton wave.

Switching and dimming functions can be linked via radio control:

- A pushbutton wave on a switch insert sys can switch a dimmer insert sys ON or OFF via radio control.
- A pushbutton wave on a dimmer insert sys can switch a switch insert sys ON or OFF via radio control.

The connection of the pushbutton wave with other radio components is carried out by pressing the pushbutton. To do so, the special function must be set for the two devices which have to be connected with each other. The operating state of the pushbutton and the successful connection are displayed by the LED located in the centre of the pushbutton.

**Connection via radio control:**

Connecting the pushbutton wave I with a dimmer insert sys II via radio control.

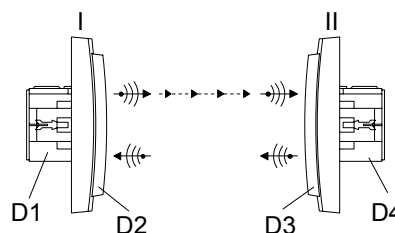

Diagram D

- D1 Dimmer insert sys I
- D2 Pushbutton wave I
- D3 Pushbutton wave II
- D4 Dimmer insert sys II

DELTA i-system	Pushbutton wave	UP 210	5WG3 210-2HB_1
DELTA profil	Pushbutton wave	UP 210	5WG3 210-2AB_1
DELTA style	Pushbutton wave	UP 210	5WG3 210-2GB_1

### 1. Pushbutton wave II: Switch to the special function (D3).

Action: Press the pushbutton rocker II in the CENTRE for at least 10 seconds.

Display: The LED of the pushbutton begins to flash slowly (approx. once per second) after 10 seconds (toggling to the special function).

### 2. Pushbutton wave I: Switch to the special function (D2).

Action: Press the pushbutton rocker I in the CENTRE for at least 10 seconds.

Display: The LED of the pushbutton begins to flash slowly (approx. once per second) after 10 seconds (toggling to the special function).

### 3. Pushbutton wave I: Transmit a linking telegram (D2).

Action: Brief operation (up to 0.4 sec.) of the pushbutton rocker I at the TOP, CENTRE or BOTTOM.

Display: The LED of pushbutton wave I flashes rapidly (3 times per second) for approx. 3 seconds if the connection has been established successfully. The LED is then extinguished and the pushbutton exits the special function. The LED of the pushbutton wave II also flashes and is extinguished. The pushbutton then exits the special function.

**Note:** There is only a limited period available for the connection as the pushbuttons wave exit the special function after 2 minutes.

The connection of pushbutton wave I with dimmer insert II is complete. When pushbutton wave I (D2) is pressed, the dimmer insert sys II (D4) is also operated via radio control.

If the connection has failed (e.g. if the distance is too great), the two pushbuttons wave exit the special function after max. 2 minutes, without confirming the success of the connection by flashing rapidly.

This procedure must be repeated if pushbutton wave I is to be connected with other dimmer inserts sys.

An unlimited number of switch inserts sys can be operated via remote control by the pushbutton wave (Diagram E).

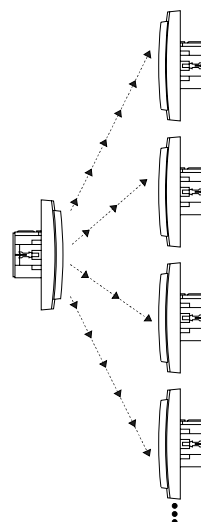

Diagram E

A switch or dimmer insert sys equipped with a pushbutton wave can be operated via remote control by up to 10 radio control pushbuttons (Diagram F).

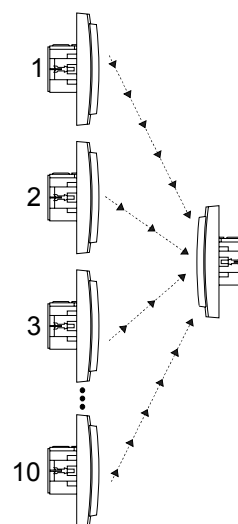

Diagram F

DELTA i-system	Pushbutton wave	UP 210	5WG3 210-2HB_1
DELTA profil	Pushbutton wave	UP 210	5WG3 210-2AB_1
DELTA style	Pushbutton wave	UP 210	5WG3 210-2GB_1

If you wish dimmer insert I (G1 in Diagram G) to be operated via remote control by pushbutton wave II (G3), the two pushbuttons wave I and II must be switched to the special function again. However, the linking telegram has to be triggered at pushbutton wave II.

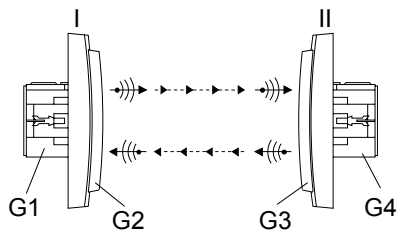

Diagram G

- G1 Dimmer insert sys I
- G2 Pushbutton wave I
- G3 Pushbutton wave II
- G4 Dimmer insert sys II

#### Procedure for deleting a connection:

Single connections can be deleted by assigning the new correlation.

Deletion of the connection between the pushbutton wave in combination I and the dimmer insert sys in combination II (Diagram D).

1. Pushbutton wave II: Switch to the special function
2. Pushbutton wave I: Switch to the special function
3. Pushbutton wave I: Trigger the linking telegram

The connection between pushbutton wave I and dimmer II is thereby deleted.

#### Deleting all connections and resetting the supplied state:

##### 1. Switch the pushbutton wave to the special function.

Action: Press the pushbutton rocker in the CENTRE for at least 10 seconds.

Display: The LED of the pushbutton begins to flash slowly (approx. once per second) after 10 seconds (toggling to the special function).

##### 2. Reset the device.

Action: Press the pushbutton rocker again in the CENTRE for at least 10 seconds.

Display: The LED of the pushbutton flashes rapidly (3 times per second) for approx. 3 seconds. The LED is then extinguished and the pushbutton exits the special function.

All connections are deleted. The device is restored to its initial state.

Connections of this pushbutton wave to other inserts are retained and must likewise be deleted.

#### Time switch mode:

Switch inserts sys or dimmer inserts sys, which are equipped with a pushbutton wave, can be operated as time switches. In this operation mode, the connected load is switched off automatically after a time interval which can be set in steps of one minute. The overshoot time can be retriggered and is reset and restarted via radio control after each pushbutton action or on receipt of an ON command. The time switch function is enabled or disabled via the special mode.

#### Activating the time switch function with a time interval which can be set in steps of one minute from 1 to 60 minutes:

##### 1. Switch the pushbutton wave to the special function.

Action: Press the pushbutton rocker in the CENTRE for at least 10 seconds.

Display: The LED of the pushbutton begins to flash slowly (approx. once per second) after 10 seconds.

##### 2. Select the time switch mode.

Action: Long operation (at least 3 seconds) of the pushbutton rocker at the BOTTOM.

Display: After 3 seconds, the LED of the pushbutton flashes rapidly (3 times per second) for approx. 3 seconds.

If the following step 3 is not carried out, the overshoot time is automatically set to 3 minutes.

If an overshoot time is required between 1 and 60 minutes, the setting must be started within 7 seconds.

DELTA i-system	Pushbutton wave	UP 210	5WG3 210-2HB_1
DELTA profil	Pushbutton wave	UP 210	5WG3 210-2AB_1
DELTA style	Pushbutton wave	UP 210	5WG3 210-2GB_1

### 3. Set the overshoot time in steps of 1 minute.

Action: Press the pushbutton rocker at the BOTTOM. The first pushbutton action sets the overshoot time to 1 minute. Each further pushbutton operation extends the period by 1 minute each time (e.g. 5 pushbutton actions for a 5 minute overshoot time).

Display: The LED of the pushbutton flashes once after each new pushbutton action.

### 4. Activating the time switch function

Action: After the last pushbutton action, no further operation for approx. 3 seconds.

Display: The LED of the pushbutton flashes rapidly (3 times per second) again for approx. 3 seconds and is then extinguished.

The time switch function is activated with the desired overshoot time.

### Disabling the time switch function and returning to normal mode:

#### 1. Switch the pushbutton wave to the special function.

Action: Press the pushbutton rocker in the CENTRE for at least 10 seconds.

Display: The LED of the pushbutton begins to flash slowly (approx. once per second) after 10 seconds.

#### 2. Disable the time switch mode, activate normal mode.

Action: Long operation (at least 3 seconds) of the pushbutton rocker at the TOP.

Display: The LED of the pushbutton flashes rapidly (3 times per second) for approx. 3 seconds and is then extinguished.

The time switch function is disabled and the device is in normal mode.

### Exiting the special function:

If the pushbutton wave is operated in the special function mode, this state is terminated by the following actions and switched back to normal mode.

1. Transmission of a linking telegram.
2. Receipt of a linking telegram.

3. Enable the time switch function (long operation (between 3 and 10 seconds) of the pushbutton rocker at the BOTTOM).

4. Switch from time switch mode to normal mode (long operation (between 3 and 10 seconds) of the pushbutton rocker at the TOP).

5. Time out after 2 minutes (no pushbutton actions are carried out and no linking telegrams are received for a period of two minutes).

### General Notes

- The operating instructions must be handed over to the client.
- Any faulty device should be returned to the local Siemens office.
- If you have further questions concerning the product please contact our technical support:

☎ +49 (180) 5050-222

☎ +49 (180) 5050-223

🌐 [www.siemens.com/automation/support-request](http://www.siemens.com/automation/support-request)