

Venetian blind actuator N 523/11
8 x AC 230 V / 6 A

5WG1 523-1AB11

Product and functional description



The Venetian blind actuator N 523/11 for control of Venetian blinds, roller shutters and awnings is a device for DIN rail mounting with N-system dimensions and a width of 8 module units. Only one AC 230V drive (motor) with electro-mechanical limit switches or with integrated electronics for disconnection at the limit positions can be connected to each of its 8 channels. The parallel operation of several drives on one channel requires the intermediate switching of a special relay.

Apart from the possibility to move the blind directly into one of its two limit positions (via EIS 1 objects) it is also possible for both the blind and the slats to be moved independently into intermediate positions, defined in percentages, by positioning commands (EIS 6 objects). Additionally, it may be differed between automatic mode and manual mode. This actuator may therefore be used in projects with tracking of blinds and/or slats according to the position of the sun.

The power supply of the Venetian blind actuator electronics is carried out via an integrated power supply unit, which is fed via the mains connection L1 for channels A and B. The mains connection of each other pair of channels may be connected to a different external conductor. If this is not required, the mains connection may be looped through, i.e. one of the L-terminals may be linked to the L-terminals of another pair of channels via a wiring jumper.

Direct operation

For direct operation (also in the event of a communication failure or if EIB communication has not yet been put into operation), eight pairs of push buttons are available on the top of the device. For direct operation, AC 230 V must be applied at the actuator. Moreover, the actuator must be switched from bus mode to direct operation via the appropriate push button with a LED. In direct opera-

tion mode, an output remains switched-on while the associated push button is pressed. A simultaneous switching-on of several outputs (i.e. a simultaneous travel of several blinds) is in direct mode not possible. As the direct operation is completely isolated from the bus communication, any active alarm or blockade mode (for blocking raising or lowering of the solar shading) is not taken into account.

Note: After an "unload" of the application program with the ETS or in the case of a failure the device will switch automatically to direct operation mode. In this case the direct mode cannot be switched off.

Application program

For configuration and loading of the application program the Engineering Tool Software (ETS) up from version ETS3 is needed.

The Venetian blind actuator N 523/11 only works together with the application program 25 A8 Venetian blind actuator 980601. This is structured so that there is sufficient basic functionality available in the supplied state for simple applications in combination with 19 basic communication objects: The always available object "Status Direct mode", an object "Alarm" that influences all channels, an object "Blockade" that also influences all channels and the two 1-bit command objects per channel enabling a blind to be moved into the upper or lower limit position, to stop the drive and to open or close the slats stepwise.

When commissioning the actuator the following objects can be added, if needed, via the parameter window "Functions, Objects":

- one object "8-bit scene",
- one object "Alarm" per channel,
- one object "Blockade" per channel,
- two 1-bit objects per channel for saving and restoring two blind / slats positions,
- one object "Blinds centrally UP / DOWN" per channel,
- three objects per channel: one for switching-over between automatic / manual mode and the two 8-bit command objects for positioning of blind and slats via percent values in automatic mode,
- one object "Status automatic mode" per channel,
- one 8-bit command object for standard operation mode (blind position in %),
- one 8-bit status object (status blind position in %),
- up to two 1-bit status objects (upper / lower limit position reached) per channel.

For a simple and quick configuration of the N 523/11 it can further be selected whether the configuration should be identically for the channels A – D and E – H or for all channels A – H or whether each channel should be configured individually.

Über einen Parameter ist pro Kanal einstellbar, ob an ihn eine Jalousie oder ein Rollladen (bzw. eine Markise, ein Antrieb zum Öffnen/Schließen einer Tür, eines Fensters oder einer Lüftungsklappe) angeschlossen ist. Bei angeschlossener Jalousie können ein 8-bit Befehlsobjekt „Lamellenstellung in % bei Standardbetrieb“ sowie ein 8-bit Statusobjekt „Lamellenstellung in %“ hinzugefügt werden.

Ferner kann pro Kanal ein Objekt „Sonnenschein“ ergänzt und über zwei Parameter eingestellt werden, welche Aktionen bei Sonnenschein EIN bzw. AUS auszuführen sind. Wird der Sonnenschutz ohne Unterbrechung von der oberen in die untere Endlage gefahren, so ist bei einer Jalousie einstellbar, in welche Zwischenstellung die Lamellen anschließend gedreht werden sollen, damit wieder etwas Tageslicht in den Raum fallen kann. Entsprechend ist bei einem Rollladen einstellbar, wie lange er aus der unteren Endlage wieder etwas hochgefahren werden soll.

Hinweis: Bei Jalousien mit Horizontal-Lamellen und einem Standard-Jalousiemotor führt das Ändern der Lamellenstellung stets auch zu einer kleinen Änderung der Jalousie-Stellung. Ein Öffnen der Lamellen ist mit einem geringen Hochfahren, ein Schließen der Lamellen mit einem geringen Herabfahren der Jalousie verbunden.

Connection example

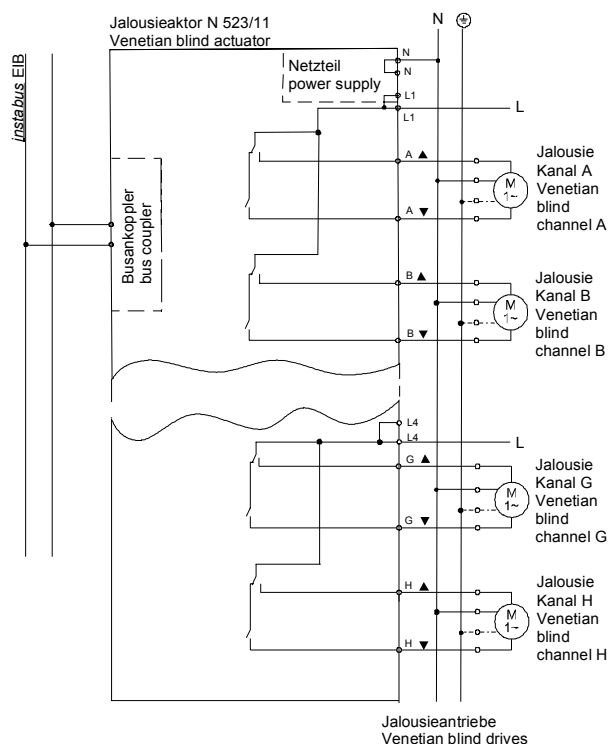

Notes for installation

The device may be used for permanent interior installations in dry locations within distribution boards or small casings with DIN rail EN 60715-TH35-7.5.



DANGER

- The device must be mounted and commissioned by an authorised electrician.
- When connecting the device, it should be ensured that the device can be isolated.
- The device must not be opened.
- For planning and construction of electric installations, the relevant guidelines, regulations and standards of the respective country are to be considered.
- In the case of motors with electronic limit switches, the switching points must be adapted on site.

Technical data

Power supply

- Bus voltage: 21V DC to 30V DC (via the bus cable)
- Bus current: 5 mA (only half a standard bus load !)
- Actuator electronics: integrated power supply unit, 230V AC, +10% / -15%, 50/60 Hz
- power consumption: min. 1.1 W, max. 4.6W

Operating elements

- 1 commissioning push button: for toggling between normal mode / addressing mode
- 1 push button: for toggling between bus / direct operation
- 8 x 2 push buttons: for direct operation of the sunblind drives, independent of the EIB

Display elements

- 1 red LED: for displaying normal mode / addressing mode (off / on)
- 1 yellow LED: for displaying bus / direct operation (off / on)
- 1 green LED: for displaying the operating voltage.

Inputs/outputs

- Mains connection: via the terminals for L1 and N in the lower terminal row
- 8 drive outputs with 2 relay contacts each,
 - 2 channels each switch the same L-conductor,
 - per relay contact:
 - rated voltage: AC 230 V, 50/60 Hz
 - rated current: 6 A (resistive load)
 - switching cycles: >25,000 at $\cos \varphi = 1$ and $I = 6$ A.

Venetian blind actuator N 523/11
8 x AC 230 V / 6 A

5WG1 523-1AB11

Connections

- Load circuit:
 - Plug-in terminals for mains voltage and outputs, insulation strip length 9...10 mm.
 - The following conductor cross-sections are permitted:
 - 0.5...2.5 mm² single-core,
 - 0.5...1.5 mm² finely stranded with connector sleeve,
 - 1.5 mm² finely stranded, untreated.
- Each L-conductor connection to the N 523/11 should be fused with a circuit-breaker of characteristic B or C for a max. rated current of 10 A.
- Bus line:
 - pressure contacts on data rail,
 - screw-less bus connection block,
 - 0.6...0.8 mm Ø single core, insulation strip length 5mm



DANGER

When looping through the L conductors, it should be noted that the maximum terminal current of 10 A, which is limited by the permitted printed conductor load, may not be exceeded.

Mechanical data

- Housing: plastic
- Dimensions: device for DIN rail mounting in N-system dimensions, width: 8 modules (1 module = 18 mm)
- Weight: approx. 500 g
- Fire load: approx. 6500 kJ
- Installation: snap-on fixing onto DIN rail
EN 60715-TH35-7.5

Electrical safety

- Degree of pollution (in accordance with IEC 60664-1): 2
- Protection type (in accordance with EN 60529): IP 20
- Bus: safety extra-low voltage SELV DC 24 V
- Device complies with
EN 50090-2-2 and EN 60669-2-1

EMC requirements

complies with EN 50090-2-2

Environmental conditions

- Ambient operating temperature: - 5 ... + 45 °C
- Storage temperature: - 25 ... + 70 °C

Markings

KNX / EIB

CE mark

In accordance with the EMC guideline (residential and functional buildings) and the low voltage guideline

Location and function of the display and operating elements

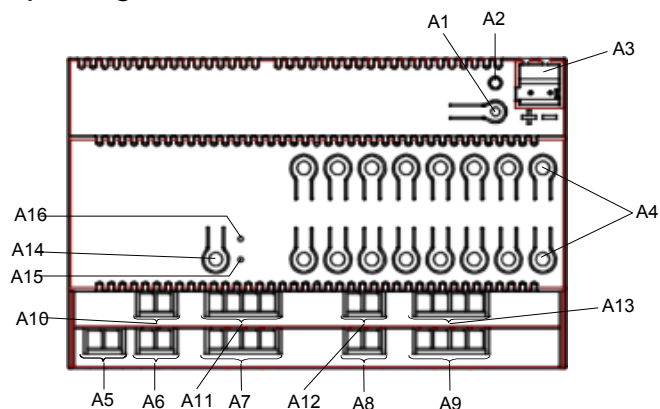

Figure 1: Location of the display and operating elements

- A1 Commissioning pushbutton
- A2 Commissioning LED
- A3 Bus terminal
- A4 Pushbuttons for direct operation sunblind Up/Down
- A5 Terminals N
- A6 Terminals L1
- A7 Terminals for sunblind Up/Down (Channels A + B)
- A8 Terminals L2
- A9 Terminals for sunblind Up/Down (Channels C + D)
- A10 Terminals L3
- A11 Terminals for sunblind Up/Down (Channels E + F)
- A12 Terminals L4
- A13 Terminals for sunblind Up/Down (Channels G + H)
- A14 Button for toggling between bus / direct operation
- A15 Yellow LED for display of direct operation = ON
- A16 Green LED for displaying the operating voltage

Mounting and wiring

General description

The device for DIN rail mounting with N-system dimensions (width 8 module units) can be inserted in N-system distribution boards, either surface- or flush-mounted, and wherever DIN rails EN 60715-TH35-7.5 are available. The contact with the bus line is carried out via the bus terminal or via the contact system to the data rail.

Assembling the DIN rail mounted device (Figure 2)

- Place the device (B1) on the DIN rail (B2) and
- rotate the device downwards until the slide switch audibly clicks into position.

Dismantling the DIN rail mounted device (Figure 2)

- Remove all the connected cables,
- press the slide switch (B3) down with a screwdriver and remove the device (B1) from the DIN rail (B2) with a swivel action.

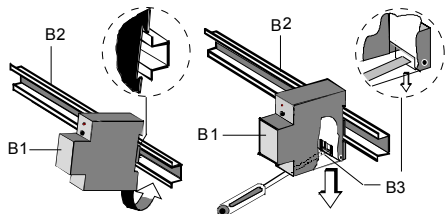

Figure 2: Assembling and dismantling the device

Removing the bus terminal (Figure 3)

- The bus terminal is located on the top of the Venetian blind actuator N 523/11 (C1)
- The bus terminal (C2) consists of two sections (C2.1, C2.2), each with four terminal contacts. Care should be taken not to damage the two test sockets (C2.3) either by accidentally connecting them to the bus conductor or with the screwdriver when attempting to remove the bus terminal.
- Carefully insert the screwdriver into the black part of the bus terminal (C2.1) and pull the bus terminal forwards out of the Venetian blind actuator N 523/11 (C1).

Note: When removing the bus terminal, there is a danger of short circuits.

Plugging in the bus terminal (Figure 3)

- Place the bus terminal (C2) in the guide slot and
- press downwards until it reaches the stop.

Connecting the bus cable (Figure 3)

- The bus terminal (C2) is suitable for single-core conductors with 0.6 ... 0.8 mm Ø.
- Strip approx. 5 mm of insulation from the conductor (C2.4) and then plug in the terminal (C2) (red = +, black = -).

Disconnecting the bus cable (Figure 3)

- Remove the bus terminal (C2) and the conductor (C2.4) from the bus cable by rotating them simultaneously backwards and forwards.

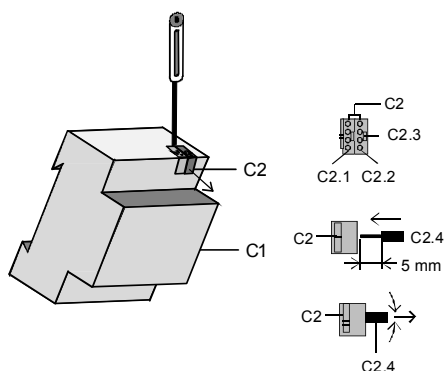

Figure 3: Connecting and removing the cable

Connecting the mains voltage and Venetian blind drives

- The connections are carried out with plug-in terminals.
- Strip approx. 9-10 mm of insulation from the conductor and slide into the respective terminal.

Mounting the insulating cap

If the device should be mounted on a DIN rail without an data rail, the contact system must be covered with the supplied insulating cap.

Removing the locating clamp: (Figure 4)

- The locating clamp (D3) encloses the contact system (D2) on the rear of the Venetian blind actuator (D1).
- Insert the screwdriver between the DIN rail mounted device (D1) and the locating clamp (D3) and remove the clamp.

Clipping on the insulation cap: (Figure 4)

Place the insulating cap (D4) on the contact system and press so that it snaps in place.

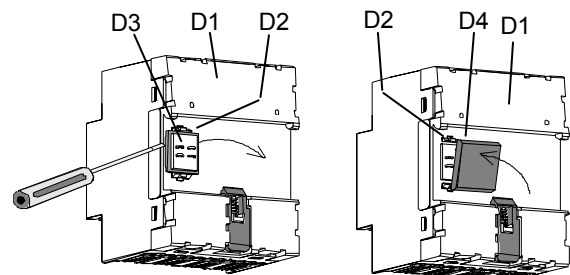
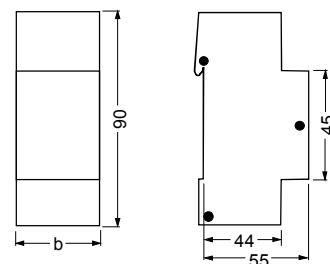

Figure 4: Covering the contact system

Dimension drawing

Dimensions in mm



b = 8 module units

1 module unit = 18 mm

General notes

- Any faulty devices should be returned to the local Siemens office.
- Should you have any additional queries, please contact our Technical Support department:

☎ +49 (0) 180 50 50-222

☎ +49 (0) 180 50 50-223

✉ www.siemens.com/automation/support-request