

## Product and Function Description



The N 305 scenes-/event controller is a device for DIN-rail mounting with N-system dimensions 1SU wide. The controller's application program includes scenes control and event program functions, either of which can be selected while setting the parameters.

### Scenes control

By a scene is meant a set of defined switching states or values, which will be sent as a result of a scene opening to a number of actuators. This is used, for example, to set the lighting and shading, as well as the screen and projector in a lecture room, for a presentation by a single press of a button.

The scenes control feature can program and recall up to eight scenes, in each of which up to eight defined switching states (e.g. lighting on/off, Venetian blinds up/down), or for values (e.g. lighting 70%, comfort temperature 22°C) can be controlled.

The defaults for the desired states in the individual scenes are set when installing the application parameters with ETS 3.0f (Engineering Tool Software). Also scenes can be changed by the user at runtime, programmed in the scene-/event controller and recalled later.

When programming a scene, the actuators integrated in this scene are first brought to the desired state (e.g. lighting 70%, Venetian blinds down, etc.) with the buttons or control elements provided for this purpose. The scenes-/event controller is then prompted by a corresponding bus telegram to interrogate the actuator states as currently set and to program them under the appropriate scene number.

The programmed values are maintained even after a restart of the scenes-/event controller (e.g. after a bus power failure).

The sending of the individual telegrams on calling up a scene can be delayed by a variable time from 0 to 30 minutes.

The following communication object data types are supported: 1-bit switching, 1-bit Venetian blinds, 2-bit forced control, 1 byte % value, 1 byte count value, 1 byte ASCII characters, 2 byte floating point value, 2 byte count value, 4 byte floating point value, 4 byte count value, 6 byte fault information, 14 byte character string, 1-bit and 8-bit scenes.

Scenes are recalled and programmed either via 1-bit switching commands or via 8-bit scene telegrams.

Individual groups in scenes can also be defined as 1-bit scene call-ups or 8-bit scene telegrams. This facilitates conversion from 1-bit to 8-bit scene openings and vice versa.

You can use additional scenes/event controllers to increase the number of scenes or group addresses within a scene.

### Event programs:

You use the event programs feature to define and process event tasks. An event opening can thus trigger the sending of several telegrams on the bus, so as to open various functions and make various settings concurrently.

The application program can construct up to eight event programs, in each of which can be triggered up to ten event tasks with various data types, such as 1-bit switching/Venetian blinds/scene, 2-bit forced control, 4-bit relative dimming, 1 byte % value 1 byte count value, 1 byte ASCII characters, 8-bit scene recall, 8-bit scene program, 2- and 4 byte floating point values (e.g. physical values such as brightness and wind speed), 2 and 4 byte count values (e.g. hours run), 6 byte fault information or 14 byte character strings.

The defaults for the desired values in the individual scenes are set when installing the application parameters with ETS 3.0f (Engineering Tool Software).

The sending of the individual event telegrams on calling up an event program can be delayed by a time variable from 0 to 120 minutes.

You can use bus telegrams with various data types such as 1-bit values, 2-bit forced control, 4-bit values, 8-bit values, 2 and 4 byte floating point and count values, 3 byte time, 6 byte fault information or 8 byte system time as event openers. Event programs are opened by means of reference values and opening conditions. Event programs can also be released and locked.

You use the ETS 3.0f (Engineering Tool Software) to allocate specific parameters and addresses and transfer these into the N 305 scene-/event controller.

### **Application program**

The "07B0 CO scenes, event 750004" application program is loaded with ETS3, Version 3.0f and upwards or Service

Patch 00697 and upwards into the N 305 scenes/-event controller and supports the following features:

- Programming and recalling 8 scenes
- with up to 8 groups.
- various data types from 1 bit to 14 bytes
- shared or separate communication objects for groups in the various scenes
- Scene recall and programming via 1-bit switching commands or 8-bit scene telegrams
- Conversion of 1-bit scene openers to 8-bit scene control and vice versa
- Free allocation of scenes to scene numbers 1 to 64 in the 8-bit scene control
- Variable sending delay from 0 to 30 minutes for each group when recalling scenes

or

- 8 event programs
- with up to 10 event tasks.
- Event tasks with data types from 1 bit to 14 bytes
- Event openings via telegrams with data types from 1 bit to 8 bytes
- Variable reference values and conditions for event opening
- Release and locking for event programs
- Variable sending delay from 0 to 120 minutes for each event task

### Installation notes

- The device can be used for fixed installation in dry internal areas, for integration in high voltage distribution boards or small housings on EN 60715-TH35-7.5 rails.



### DANGER

- The system may only be installed and commissioned by a licensed electrician.
- Exposed sections of rail with integrated data rails are to be covered with the lid 5WG1 192-8AA01.
- The relevant safety and accident prevention rules are to be obeyed.
- The system must not be opened.
- When planning and installing electrical systems, the relevant national directives, rules and regulations of the country in question are to be obeyed.

### Technical specifications

#### Power supply

- Bus voltage: supplied via the bus line (DC 21...30 V, SELV)
- Bus current: 6 mA

#### Control elements

- 1 programming button: to change between normal and addressing modes

#### Display elements

- 1 red LED: for checking bus voltage and to indicate normal mode (LED = Off)/addressing mode (LED = On)
- 1 yellow LED: Standby

#### Connections

- KNX *EIB* bus line:
  - Pressure contacts on data rail
  - Screwless bus terminal , 0.6 ... 0.8 mm Ø solid, stripped length 5 mm

#### Mechanical specifications

- Casing: plastic
- Dimensions: device for DIN-rail mounting with N-system dimensions: 1SU (1SU = 18 mm)
- Weight: approx. 65g
- Fire load: appr. 1410 KJ ± 10%
- Mounting: Quickfix on rails to EN 60715-TH35-7.5

#### Electrical safety

- Degree of pollution (to IEC 60664-1): 2
- Protection class (to EN 60529): IP 20
- Protection class (to IEC 61140): III
- Overvoltage category class (to IEC 60664-1): III
- Bus: safety extra low voltage SELV DC 24V
- Device complies with EN 50090-2-2 and IEC 60664-1

#### Reliability

Failure rate: 170 fit at 40°C

#### EMC criteria

- Complies with EN 61000-6-2, EN 61000-6-3 and EN 50090-2-2

#### Environmental specifications

- Climatic conditions: EN 50090-2-2
- Ambient temperature in operation: - 5 ... + 45 °C
- Storage temperature: - 25 ... + 70 °C
- Relative humidity (non-condensing): 5% to 93%

#### Markings

- KNX *EIB*

**CE mark**

- to EMC directive (residential and functional building)

**Location and functioning of the display and operating elements**

Figure A: Location of the indicating and operating elements

- A1 Red LED: LED for indicating normal mode (LED Off) or addressing mode (LED On); it goes out automatically after transferring the physical address
- A2 Button for switching between normal mode and addressing mode for transferring the physical address.
- A3 Green LED: Device standby indicator.
- A4 Plug for bus connection terminal
- A5 Type label

**Mounting and wiring**Overview

The N-dimension modular installation device can be used in low voltage distribution boards (surface- or flush-mounted) and anywhere that rails to EN 60715-TH35-7.5 are in use.

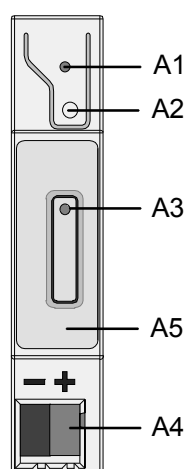
The bus line is connected via a bus terminal or via the contact system for the data rail.

**Mounting the modular installation device (Figure B)**

- Hang the device (figure 1) in the rail (figure 2) and
- tilt the device (figure 1) backwards until you hear the slide click into position.

**Dismounting the modular installation device (Figure C)**

- Remove all bus lines,
- use a screwdriver to press down the slide (C3) and
- ease the modular installation device (C1) out of the standard rail (C2).

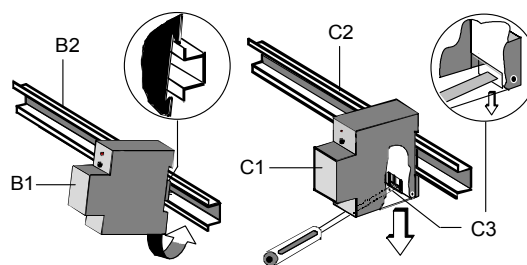

Figure B: Mounting and figure C: Dismounting the device

**Pull off the bus terminal (figure D)**

- The bus terminal (D2) is at the bottom front of the N 305 scene-/event controller (D1).
- The bus terminal (terminal block) (D2) consists of two parts (D2.1, D2.2), each with four terminal contacts. You must take care that both test sockets (D2.3) are not damaged, either with the bus lead (accidental attempt to plug in) or with the screwdriver (when trying to remove the bus terminal).
- Push the screwdriver carefully into the wire connection slot of the grey part of the bus terminal (D2.2) and then pull the bus terminal (D2) forwards out of the device (D1).

**Note:**

Do not lever the bus terminal outwards from below!  
Danger of short circuit!

**Connect the bus terminal (figure D)**

- Plug the bus terminal (D2) into the guidance groove and
- press rearwards to the end stop.

Connecting the bus line (figure D)

- The bus terminal (D2) is suitable for solid leads with a diameter of 0.6 ... 0.8 mm.
- Strip the insulation from the lead (D2.4) to a distance of approx. 5 mm and plug it into the terminal (D2) (red = +, black = -).

Disconnecting the bus line (figure D)

- Pull off the bus terminal (D2) and pull out its lead (D2.4) by turning it alternately backwards and forwards.

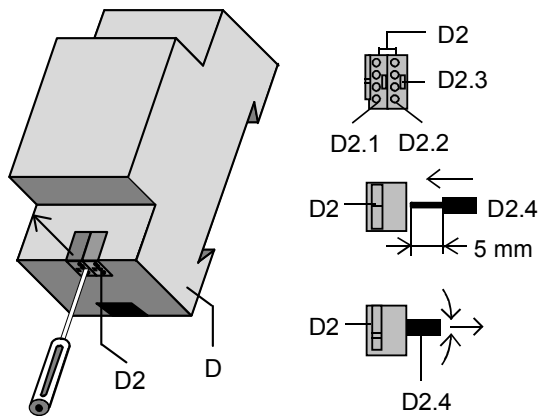

Figure D: Plugging in/removing the bus terminal

Mounting the insulating cap

If the device is mounted on a rail without a bonded data rail, then the contact system is to be covered with the insulating cap supplied on delivery.

Removing the fixing (figure E):

- The fixing (E3) encloses the contact system (E2) on the rear of the device (E1).
- Insert a screwdriver between the modular installation device (E1) and the fixing (E3) and lever out the fixing.

Snapping on the insulating cap (see figure E):

Plug the insulating cap (E4) on to the contact system (E2) and snap it on by pressing.

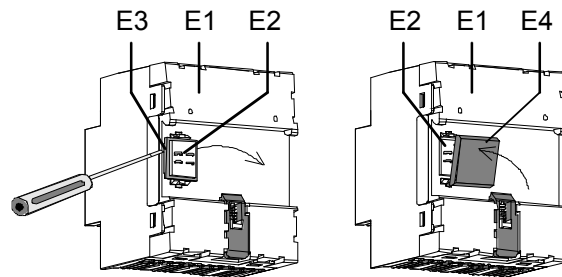
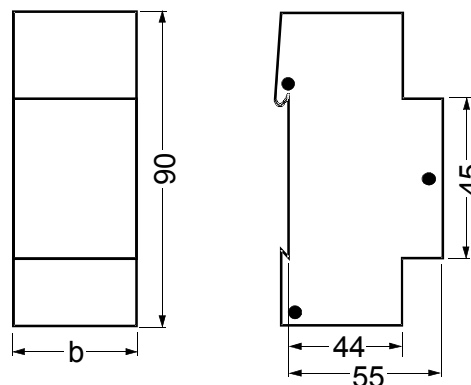

Figure E: Uncovering the contact system

Dimensioned picture

Dimensions in mm



b = 1 SU

1 division (SU) = 18 mm

General notes

- Any faulty device is to be returned to the local Siemens office.
- If you have further questions concerning the product, please contact our Technical Support:

+49 (0) 180 50 50-222

+49 (0) 180 50 50-223

[www.siemens.de/automation/support-request](http://www.siemens.de/automation/support-request)