

Instabus / DALI Gateway N 141

5WG1 141-1AB01

Product and functional description



The instabus / DALI gateway N 141 is a KNX EIB device with one DALI output to which up to 64 DALI actuators (e.g. DALI ballasts) can be connected to. It is not allowed to connect DALI sensors to the output of the N 141. DALI (Digital Addressable Lighting Interface) is a bidirectional communications interface in accordance with IEC 60929, whose specification has been defined by manufacturers of electronic ballasts. It not only enables the receipt of e.g. switching and dimming commands but also the sending of status information such as the failure of a lamp or the report of a detected error in the electronic ballast. According to IEC 60929 up to 64 DALI devices can be connected to a DALI bus line and can each be assigned an individual device address.

The instabus / DALI-Gateway N 141 can be used to control up to 64 DALI devices over the EIB. They can be switched and dimmed either individually or in groups. The N 141 also enables the detection and transmission of DALI status and failure information. An individual name, a group, scenes and parameters (refer to the application program description) are allocated to the individual DALI electronic ballasts during commissioning with the ETS (Engineering Tool Software).

The power supply unit integrated in the N 141 supplies the gateway electronics and generates the DALI bus voltage. Additionally it enables the operation of the gateway and a direct switching of all lamps controlled over its DALI output even if the N 141 has not yet been commissioned with the ETS or if the communication via the EIB has been interrupted. For this purpose, the N 141 has a pushbutton located bottom left on its front plate

for switching On the "Direct mode" as well as for switching back to the "Bus mode". When this pushbutton has been pressed for the first time the yellow LED lights up permanently to indicate direct mode. Then all lamps controlled over the DALI bus can be together switched On or Off via the relevant two pushbuttons on the front plate of the gateway such as via a bus pushbutton: pressing the upper pushbutton briefly switches the channel On while pressing the lower push button briefly switches the channel. A red LED integrated in the upper push button is used to indicate the state of the lamps by a continuous light and to indicate an error (e.g. a DALI bus, ballast or lamp failure) by flashing. If the direct mode button is pressed for a second time, the yellow LED to indicate direct mode is extinguished and the N 141 is switched to "Bus mode".

Note: If individual communication with each individual DALI device is not required and you wish for example to simply connect a group of dimmable fluorescent lamps in parallel and control them in the same way as you would previously have connected and controlled dimmable electronic control gear (ECG) with a 1...10 V interface, this is also possible with the switch/dimming actuator N 525E. Status and error signals are also detected by the N 525E and transmitted, whereby these signals are assigned to the respective group and not to an individual DALI device.

Application program

25 CO instabus / DALI Gateway 802701

Connection example

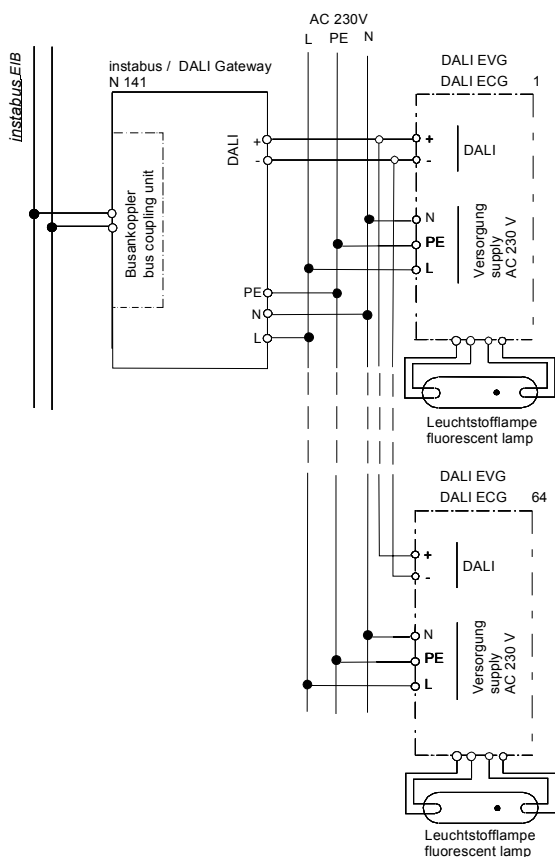

Installation notes

- The device can be used for permanent installation in dry, interior rooms and for insertion in distribution boards or miniature housings.



WARNING

- The device must be mounted and commissioned by an authorised electrician.
- Unoccupied sections of DIN rail with data rail inserted must be protected with the cover 5WG1 192-8AA01.
- When connecting the device, it should be ensured that the device can be isolated.
- The device may not be opened.
- When planning and installing electrical installations, the relevant guidelines, regulations and specifications of the respective country must be observed.

Technical data

Power supply

- EIB Bus voltage: carried out via the bus line

- EIB bus current: 5 mA (only half a standard bus load !)
- Electronics and DALI output:
 - integrated power supply for AC/DC 110-240 V, 50-60 Hz
 - power consumption: max. 7 W

Inputs/outputs

- Mains connection: 3-pole (PE, N, L)
- DALI output (according to IEC 60929):
 - max. 64 DALI devices with ≥ 8 kOhm input impedance
 - DALI bus voltage: approx. DC 19 V, floating, short-circuit-proof

Operating elements

- 1 learning push button: for toggling between normal mode / addressing mode
- 1 push button: for toggling between bus mode / direct mode
- 2 push buttons: for switching all electronic ballasts ON / OFF

Display elements

- 1 red LED: for checking the bus voltage and for displaying normal mode / addressing mode
- 1 green LED: for displaying the 230 V operating voltage
- 1 yellow LED: for displaying direct mode / bus mode
- 1 red LED per push button: for ON / OFF status indication (only in direct mode) and failure indication by blinking with 1 Hz (communication or illuminant failure)

Connections

- Plug-in terminals for mains voltage and DALI output, insulation strip length 10 ... 11 mm
- The following conductor cross-sections are permitted:
 - 0.5 ... 3.3 mm² (AWG 12) single-core
 - 0.5 ... 3.3 mm² (AWG 12) stranded multi-core
 - 0.5 ... 3.3 mm² (AWG 12) finely stranded, untreated
 - 0.5 ... 1.5 mm² finely stranded, with connector sleeve
- The supply cable to the N 141 must be fused with a circuit-breaker of characteristic B or C for a max. nominal current of 6 A!
- EIB Bus line: Pressure contacts on data rail and bus terminal

Mechanical data

- Housing: plastic
- Dimensions: DIN rail mounted device in N-system dimensions, width: 4 module units (1 module unit = 18 mm)

Instabus / DALI Gateway N 141

5WG1 141-1AB01

- Weight: approx. 150 g
- Fire load: approx. 3400 kJ
- Installation: Snap-on mounting on DIN rail
EN 60715-TH35-7.50

Electrical safety

- Degree of pollution (according to IEC 60664-1): 2
- Protection type (in accordance with EN 60529): IP 20
- Overvoltage category (according to IEC 60664-1): III
- Bus: safety extra-low voltage SELV DC 24 V
- Device complies with: EN 50090-2-2 and EN 60669-2-1

EMC requirements

- Complies with EN 50090-2-2

Environmental conditions

- Climatic withstand capability: EN 50090-2-2
- Ambient operating temperature: - 5 ... + 45 °C
- Storage temperature: - 25 ... + 70 °C
- Relative humidity (not condensing): 5 % to 93 %

Markings

- KNX *EIB*

CE mark

- In accordance with the EMC guideline (residential and functional buildings), low voltage guideline

Location and function of the display and operating elements

Figure 1: Location of the display and operating elements

- A1 Button for toggling between normal / addressing mode for transferring the physical address
- A2 LED (red) for displaying normal mode (LED off) or addressing mode (LED on); it is automatically extinguished once the physical address has been transferred
- A3 Plug for bus connecting terminal
- A4 Pushbuttons for direct operation (all lamps On / Off)
- A5 Red LED
direct mode: status all lamps (On/Off)
display DALI – failure
flash N times – approx. 1s break – flash N times ...
N = 1: -> 230V connect to DALI – Input!
N = 2: -> shorted DALI – cable!
N = 3: -> low DALI – voltage!
N = 4: -> no DALI – device connected!
- A6 Terminals for the DALI bus cable (D+, D-)
- A7 Terminals for protective earth, neutral and phase conductor (PE, N, L)
- A8 LED (yellow) for displaying when direct mode = On
- A9 Button for toggling between bus / direct mode
- A10 LED (green) for displaying the operating voltage

Installation and wiring

General description

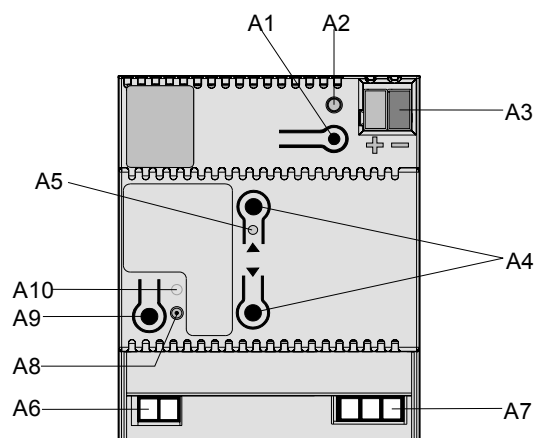
The DIN rail mounted device in N system dimensions (width 4 module units) can be inserted in N distribution boards, surface- or flush-mounted and wherever DIN rails EN 50022-35 x 7.5 are available. The connection with the bus line is either carried out via a bus terminal or via the contact system to the data rail.

Installing the DIN rail mounted device (Figure 2)

- Suspend the DIN rail mounted device (B1) on the DIN rail (B2) and
- Rotate the DIN rail mounted device backwards until the slide switch audibly clicks into position.

Dismantling the DIN rail mounted device (Diagram 2)

- Remove all the connected cables,
- press the slide switch (C3) downwards with a screwdriver and
- remove the DIN rail mounted device (C1) from the DIN rail (C2) with a swivel action.

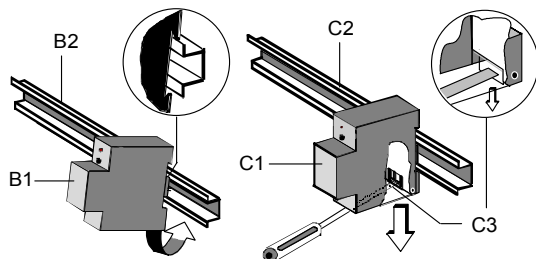

Figure 2: Installing / dismantling the DIN rail mounted device

Removing the bus terminal (Figure 3)

- The bus terminal is located on the top of the N 525E (D1)
- The bus terminal (D2) consists of two sections (D2.1, D2.2), each with four terminal contacts. Care should be taken not to damage the two test sockets (D2.3), either by accidentally connecting them to the bus conductor or with the screwdriver (when trying to remove the bus terminal).
- Carefully insert the screwdriver in the wire entry slot underneath the bus terminal (D2) and pull the bus terminal forwards out of the N 525E (D1).

Note: Care should be taken as there is a risk of shorting the device!

Connecting the bus terminal (Figure 3)

- Place the bus terminal in the guide slot and press the bus terminal (D2) backwards until it reaches the stop.

Connecting the bus cable (Figure 3)

- The bus terminal (D2) is suitable for single-core conductors with 0.6... 0.8 mm Ø.
- Strip approx. 5 mm of insulation from the conductor (D2.4) and plug in the terminal (D2) (red=+, black=-).

Disconnecting the bus cable (Figure 3)

- Remove the bus terminal (D2) and the conductor (D2.4) out of the bus cable by rotating it backwards and forwards.

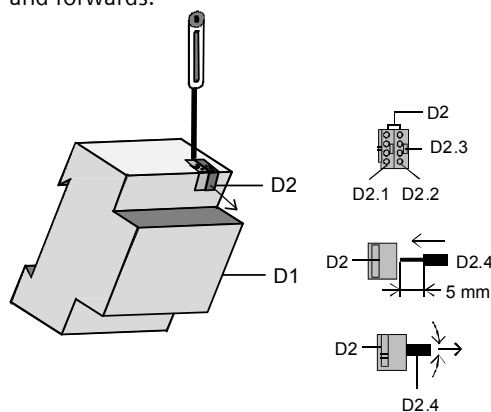

Figure 3: Connecting and disconnecting the cable

Connecting mains voltage and DALI bus cables

- The connections are designed with plug-in technology.
- Strip approx. 10-11 mm of insulation from the conductors and slide in the respective terminal.

Cross-sections:

- The following conductor cross-sections are permitted:
 - 0.5 ... 3.3 mm² (AWG 12) single-core
 - 0.5 ... 3.3 mm² (AWG 12) stranded multi-core
 - 0.5 ... 3.3 mm² (AWG 12) finely stranded, untreated
 - 0.5 ... 1.5 mm² finely stranded, with connector sleeve
- The mains connection must be fused with a circuit-breaker of characteristic B or C with a max. nominal current of 6 A!

Mounting the insulating cap

- If the device should be mounted on a DIN rail without a data rail, the contact system must be covered with the supplied insulating cap.

Removing the locating clamp (Figure 4)

- The locating clamp (E3) encloses the contact system (E2) on the rear of the DIN rail mounted device (E1).
- Insert the screwdriver between the DIN rail mounted device (E1) and the locating clamp (E3) and remove the clamp.

Instabus / DALI Gateway N 141

5WG1 141-1AB01

Clipping on the insulating cap: (Figure 4)

- Place the insulating cap (E4) on the contact system and press so that it snaps in place.

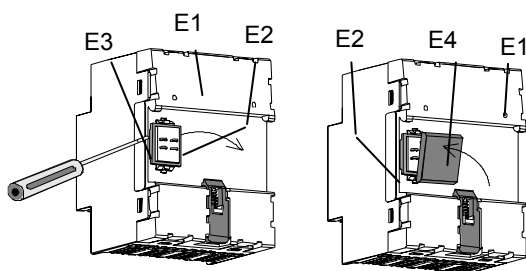
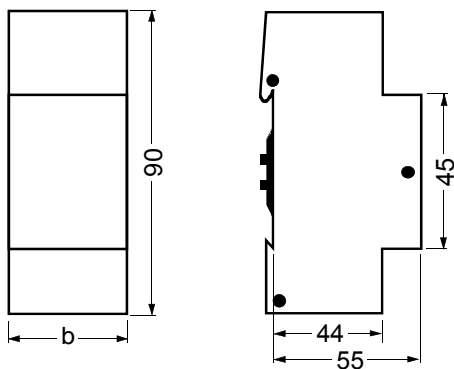

Figure 4: Covering the contact system

Dimension drawing

Dimensions in mm



b = 4 module units (1 module unit = 18 mm)

General notes

- Any faulty devices should be returned to the local Siemens office.
- If you have further questions about the product, please contact our Technical Support:

☎ +49 (0) 180 50 50-222

☎ +49 (0) 180 50 50-223

✉ www.siemens.com/automation/support-request