

Operating Manual for 4-way Universal dimmer **SDK-U4-10 (EIB)**

Art. No. 215.0143.00

1 Introduction



The 4-way universal dimmer is suitable for use with all conventional dimmable types of lighting. There are 4 separate dimmer inputs and outputs, each with a load capacity of 570W. The control circuits automatically detect the connected load, and automatically change over from forward phase control to reverse phase control, and regulate the light output using a suitable control characteristic (Ueff).

- **Control of incandescent lamps, high-voltage halogen filament lamps, as well as low voltage halogen lamps with magnetic and electronic transformer.**

The 4-way universal dimmer is controlled by the EIB bus system. By setting parameters accordingly, the device can accomplish the following functions:

- **dimming functions**
- **lighting scenes functions**
- **sequence controls**
- **time functions**
- **blocking functions**
- **switching functions**
- **error and status messages**

1.1 Intended use

The universal dimmer is intended only for the control of light sources, and is designed for indoor use in electrical control panels.



Note
The manufacturer (and/or supplier of the SDK-U4-10 (EIB)) is not liable for any personal injury or property damage whatsoever, arising from use other than the intended use or from failure to comply with the information set out in this operating manual.

2 Safety Instructions

2.1 Responsibilities

The person installing the unit is responsible for ensuring protection against personal injury and property damage, and also for the provision of the necessary information to the installation owner. He is also responsible for ensuring compliance with the applicable general health and safety regulations and the specific safety regulations applying to work on medium-voltage electrical installations.

2.2 Residual hazards



Potential residual hazard from contact with medium-voltage (230 VAC) conductors.

When the SDK-U4-10 (EIB) is used for its intended purpose, the equipment meets all relevant standards and regulations relating to the avoidance of personal injury and property damage. However, residual hazards arising from power-conductors cannot be completely eliminated. The key areas with a potential residual hazard are shown in the adjacent illustration.

2.3 Regulations specific to the equipment

DANGER!



The SDK-U4-10 (EIB) universal dimmer must be installed and used only in a perfect condition and in accordance with the operating manual. The unit must be disconnected from the power supply before any electrical terminals (power supply and dimmer output, etc.) are connected or disconnected. Work carried out on live terminals can result in severe injury from electric shocks.

Output LD is not disconnected from the power supply when the dimmer is switched off. A separate automatic safety cut-out must be installed in the power feed.

Attention!



The universal dimmer SDK-U4-10 (EIB) cannot be used for a high voltage transformer for neon signs.

If the universal dimmer SDK-U4-10 (EIB) is used with a transformer for low voltage incandescent lamps, there must be assured that the inrush current never exceeds 22 A (danger with short connections, cold spiral-wound filament, aso.)

Attention!



Connection and disconnection of the load or parts of the load is not permitted during operation.

Attention!



Into the power feed there must be a miniature circuit breaker or a fuse adapted to the load (maximum 10A type B).

Connecting other load through the terminals "N" and "L" (looping) is not allowed.

3 Installation

The SDK is mounted on a top-hat rail. It is clipped in to the rail from below. Gentle pressure is then applied to the top front to snap it in place.

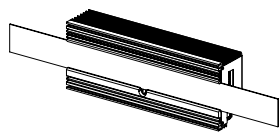
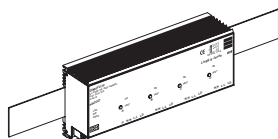

Installation position:	Terminals horizontal
Horizontal spacing:	min. 1mm
Minimum vertical rail grid spacing:	115mm (90+25mm) (excluding conduit)
Recommended vertical rail grid spacing:	160mm (with 40mm conduit)

Each individual SDK generates 23W dissipation power under rated load. If a number of dimmers are installed in an electrical cabinet, measures must be taken to ensure that the temperature of the individual control units does not exceed 70°C.

4 Control Modes

The SDK is controlled by a EIB standard bus.
The following illustrations show the connections used and the required settings.

4.1 Connection of the EIB bus

The EIB bus contains power supply (24V) as well as the bus signal (telegram) in a 2wire twisted pair cable.
Connect the EIB bus to the two plug-in terminals marked "BUS". Connect the negative polarity to the black and the positive to the red plug-in terminal.

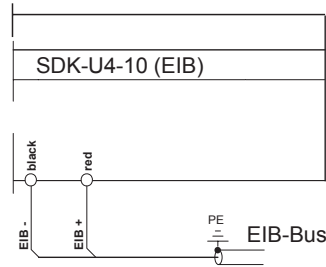

4.2 Operating Parameters

The system programmer can set the following parameters for each channel:

- Operating mode (each channel separately or two parallel)
- Switching functions
- Time functions
- Lighting scenes functions
- Sequence control
- Blocking functions
- Operating and error status

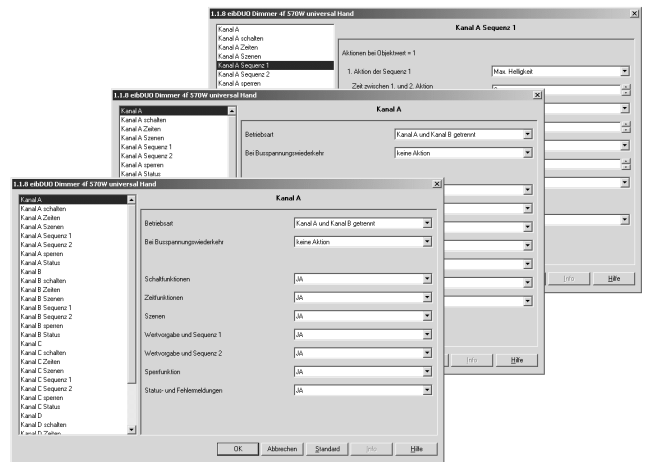

4.3 Commissioning

When delivered, the SDK-U4-10 (EIB) has no device and group addresses.
The needed functions can be activated in the parameter setting. During project management with the ETS software only the activated objects will be visible.

Important:

Due to the built in bus coupler (BCU 2.1) the following measures must be taken before commissioning the device:

for ETS 2.0 V1.2 / 1.3 and for ETS 3.0

- service packs and all patches must be installed
- product data base must not be older than 09/2005

The application program must always be completely copied into the device. Partial copies lead to malfunctioning.

For announcing the device to the system, press the "PROG"-button with a small screwdriver. The red LED will light up during the transmission.

5 Load Circuit

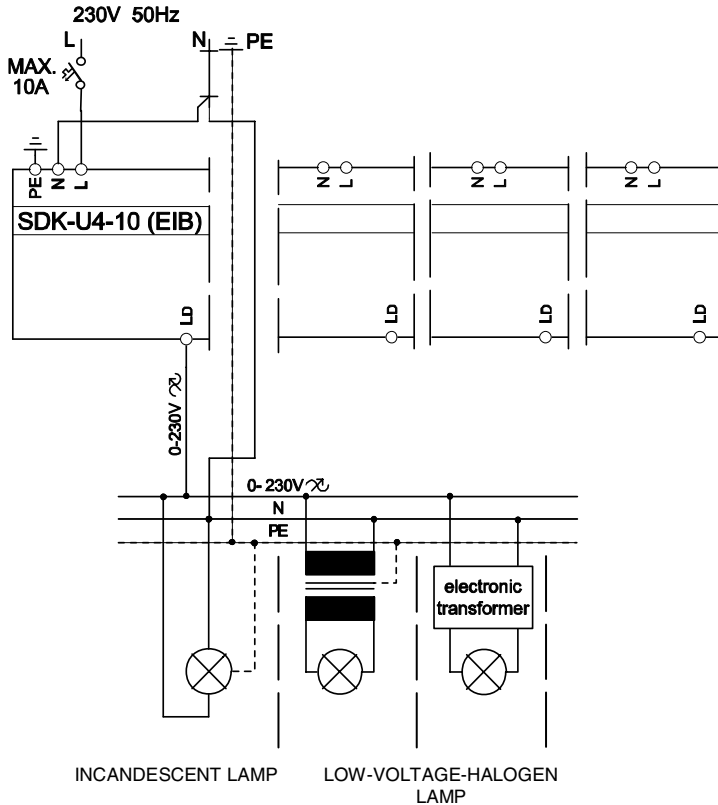

The 4-way universal dimmer is capable of controlling 230V incandescent lamps, low voltage halogen lamps **with electronic or magnetic transformers** up to a maximum current of 2.5 A (570 W). The dimmed voltage is present at output "LD". The universal dimmer uses transistor circuitry to control the output voltage.

Mixed load (inductive and capacitive) on one output are not allowed!

From one channel to the next channel on the same dimmer the connections "N" and "L" may be looped (two terminals per connection). It is not allowed to connect another device through these terminals.

Test function:

Each circuit can be individually tested by pressing the relevant "TEST"-key on the power section. One press of the key switches the circuit on. A second, long press activates dimming, while a third press reverses the dimming into brightening. To switch off, it is necessary to interrupt the power supply (safety cut-out). A value generated with the test-key is overwritten if another value is demanded from the EIB bus (and vice versa).

5.1 Parallel power connection

To increase the power, two dimming circuits (A+B and C+D) can be software-connected in parallel (2 x 570W = 1140W).

- The circuits connected together must be in the same phase.
- On the power section, the contacts of the common dimming circuits must be connected together (L with L, N with N and LD with LD).
- The parallel connection must be software-programmed.

6 LED Indicators on the Dimmer

The dimmer has 1 LED on the interface section and 4 LEDs on the power section:

Interface section

Power section

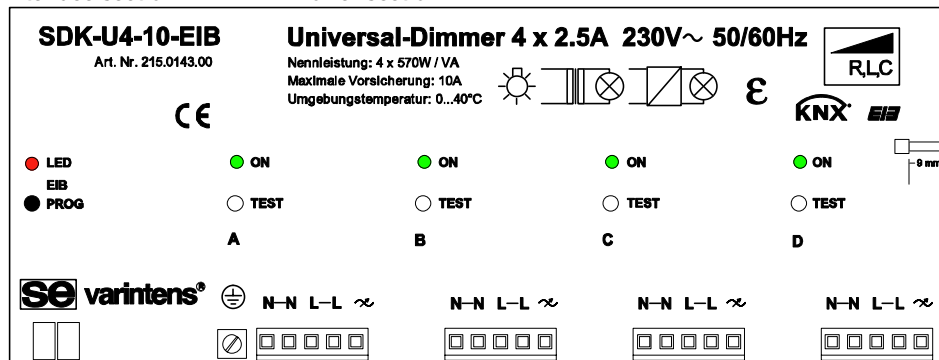

Interface section:

Red LED	ON	During pressing the programming button the LED is on.
	OFF	Unit is operating normally or supply is not connected.

Power section:

Green LED 1-4	ON	Dimming circuit on (over the EIB bus or the "Test" keys).
	OFF	Dimming circuit off.

7 Fault Finding and Elimination

Fault	Remedy
Lamp does not brighten.	The relevant lighting circuit can be dimmed or brightened by pressing one of the keys on the power section, after removing the bus cable. If the circuits do not respond, check the load circuit wiring. Check the bus voltage on the SDK (red LED must come on while pressing the programming button).

8 Technical Data

Dimensions:

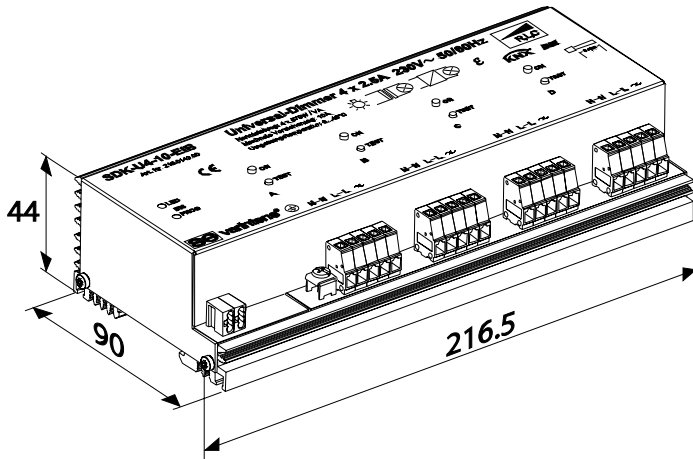

Electrical data: per channel

Mains voltage:	230 V ±10%
Mains frequency:	50 / 60 Hz
Preliminary fuse:	10 A max. (type B)
Dimming output technology:	Transistor-driven forward phase control / reverse phase control
Maximum load, dimming output:	570 W / VA (2.5A) resistive / inductive / capacitive
Minimum load, dimming output:	5 W resistive
Leakage power at rated load:	5.7 W at rated load
Leakage power on standby:	1.4 W
Cooling:	Natural air circulation
No-load voltage:	Approx. 55 V _{rms}
Short-circuit protection:	Electronic fast cut-off
Overload protection:	Temperature monitoring. (trigger value approx. 85°C)
Symmetry errors:	Not measurable
Impulse switching flank:	100µs, rated load with inc.-lamp
Operational and fault indicator:	Green "Run" LED per channel
Keys (integrated single-key control):	On / brighter / dimmer. (for test purposes at initial start-up)
Insulation:	2500 V betw. interface / dimmer
Switch-on delay:	approx. 1s (mains switch-on)

The product data base for the SDK-U4-10 (EIB) can be found in the "download"-section on www.se-ag.ch.

Would you like more «varintens» information? Visit our web site!
www.se-ag.ch
 e-mail: info@se-ag.ch

Type	SDK-U4-10 (EIB)
Article number	215.0143.00
Mechanical data:	
Case:	Steel sheet with aluminium cooler
Dimensions:	Width: 216.5 mm Height: 90 mm Depth: 44 mm (from top-hat pr.)
Weight:	850 g
Installation:	On DIN top-hat profile rails 35 mm
Mains power connection:	4 plug-in terminals max. 2.5 mm ²
Load connection:	1 plug-in terminal max. 2.5 mm ²
Control connections:	2 plug-in terminals max. 0.8 mm ²
Ambient conditions:	
Ambient temperature:	ta 0-40 °C max. Do not block airflow at cooler.
Storage temperature:	70 °C max.
Air humidity:	10%...80% relative air humidity, non-condensing
Case temperature:	tc 70 °C max.
IP protection:	IP20
Control:	
Operational voltage:	28VDV (from EIB-Bus)
Bus protocol:	EIB
Indications:	LED (Program) red
Control elements:	Programming button
CE mark:	as per 89/336/EWG and 73/23/EWG
EN 60669-2-1	Safety requirements
EN 55015	Interference transmission
EN 55014-2 (VDE 0875)	Radio interference
EN 61000-3-2	Harmonics

se Lightmanagement AG
 Güterstrasse 11, CH-8957 Spreitenbach,
 Switzerland
 Tel. +41 56 418 76 11, Fax +41 56 401 49 86