

25 A16 binary, blinking before off 981C01

Use of the application program

Product family: Output
 Product type: Switching actuator
 Manufacturer: Siemens

Name: Switching actuator N 567/22
 (16x AC 230V / 10A)
 Order no.: SWG1 567-1AB22

Functional description

The switching actuator N 567/22 needs the application program "25 A16 binary, blinking before off 981C01". There is a distinction between bus mode and direct mode. In bus mode each channel can be provided with a communication object for switching, for status check and for logic operation. In addition it is possible with each channel to change over from permanent switch-on to time-limited switch-on (e.g. for cleaning light) using an optional object "Night mode".

If required it is possible to activate an 8-bit scene control function, which is integrated in the application program, and to incorporate each channel in up to 8 scenes. In addition you can choose whether all channels shall be configured jointly and hence identically or each channel separately and individually.

The following parameter settings are possible per channel:

- Operating mode (normal / time switch mode)
- Relay mode (normally open contact / normally closed contact)
- Logic operation (none, AND, OR)
- On delay
- Off delay
- on-period in night mode
- Warning before Off by multiple flashing in case of a time-limited on-period in night mode or in time switch mode
- Switching state after mains voltage recovery.

The application program can be loaded with ETS2 V1.3 or any higher version.

Bus mode / direct mode

The switching actuator N 567/22 has an integrated power supply unit for AC 230 V in order to supply power to the actuator electronics. The power supply unit enables operation of the actuator and direct switching of the actuator channels in "direct mode" even if no bus voltage is available, the N 567/22 still has to be taken into operation with the ETS (Engineering Tool Software) or communication over the bus has been interrupted.

With the N 567/22, "direct mode" is switched on by means of a pushbutton at bottom left on the upper side of the actuator. When this pushbutton is pressed for the first time, the yellow LED shines with a steady light to indicate the direct mode. In direct mode, each channel can be switched by a toggling function using the pushbutton assigned to it on the upper side of the actuator: pressing the pushbutton once switches on the channel, pressing it a second time switches off the channel. The switching state of the channel is indicated by a red LED integrated in the pushbutton.

A parameter is available to set whether direct mode can be switched on permanently or for a limited time. In the default setting, direct mode is limited to an on-period of 15 minutes. Each time the pushbutton is pressed in direct mode the timer for limiting the on-period is restarted with the parameterized on-period. If the on-period expires without the pushbutton being pressed again, direct mode is switched off automatically and "bus mode" reactivated (provided communication over the bus is possible). Alternatively, direct mode can be terminated at any time with another press of the "direct mode" pushbutton. The yellow LED for indicating direct mode then goes out and the actuator is back in bus mode. Switching states of outputs (channels) which have been changed in direct mode will be kept after switching back to bus mode. Exception: Switching and scene calling commands received over the bus while direct mode is active are buffered and automatically executed after having returned to bus mode.

In bus mode, nothing happens if you press the pushbuttons for directly switching a channel on or off which are located on the upper side of the actuator.

Behavior on mains voltage failure / recovery

The actuator electronics is powered from the mains supply; a power failure thus results in failure of the actuator. With the N 567/22, all channels remain in their respective switching state when there is a power failure. However, for each channel it is possible to select which switching state is to be adopted after power recovery: the state that existed before the power failure, on or off. When direct mode of the N 567/22 is activated, in case of a mains failure the N 567/22 is automatically switched to bus mode at mains voltage recovery. In this case the status of each output corresponds to the setting of the parameter "Output state at mains voltage recovery".

Parameter window "Functions, Objects"

In the supplied state, the communication object "Status direct mode" is available as well as the object "Switching On/Off" which is available for each channel. The commissioning engineer can set via the parameter window

25 A16 binary, blinking before off 981C01
--

"Functions, Objects" which functions and objects he would like to use in addition to the default objects.

Configuration of channels A-H (respectively a-h): This parameter is used to set whether the configuration of the channels A-H (respectively a-h) shall be identical (i.e. the same) or individual (i.e. different). If you select "identical for all channels", only one parameter page for the joint configuration of all channels appears; if you select "individual for each channel", one parameter window per channel is shown.

ON time during direct mode: This parameter is used to set whether to permit permanent or time-limited activation of direct mode; if time-limited direct mode is selected you can then also set after how much time the time-limited mode is to be reset to bus mode.

8-bit scene control: You can select whether a communication object is to be added to the 8-bit scene control and whether an additional parameter page for assignment of the 8-bit scenes per channel is to be shown. Each actuator channel can be integrated in up to 8 scenes.

Night mode channels A-H (respectively a-h): You can select whether a "Night mode, On/Off" object and the corresponding function are to be added per channel. When night mode is activated, a channel can no longer be switched on permanently but only for a limited period (e.g. for cleaning light). The desired on-period in night mode can then be set with another parameter.

Status objects switch channels A-H (respectively a-h): You can select whether a communication object "Status switch" is to be added per channel. If so, a parameter is added per channel to define when this object is to be sent ("using read request only" or "on change of status").

Parameter window "Channels A-H" / "Channel X" ("Channels a-h" / "Channel x")

Depending on whether the setting permits identical (i.e. the same) or individual (i.e. different) configuration of all channels, only one parameter page for the joint configuration of all channels or one parameter page per channel is shown.

Operating mode: This parameter is used to set whether the channel is to work in "Normal mode" as a "normal switch" or whether it is to work as a "Time switch" that is activated by means of a switching or scene calling command and automatically switched off after the configured on-period expires.

If "Time switch" is selected, the parameter "ON time" will also be shown. If another switching or scene calling command is received during time switch operation and an active on-period, the timer will be reset to its initial value and the operating interval extended accordingly. Before expiration of the set on-period, if the warning

function was activated (via the parameter "Blinking before Off"), then the switching channel will not be permanently switched off right away; it will first be switched off for about 1 s and then switched on again for about 10 s. This is repeated another two times before the channel is then permanently switched off. If the channel is used for lighting control, a user is thus given advance warning and can switch the lighting back on again.

Relay mode: This parameter can be used to set if the corresponding channel shall be operated as a normally open contact or a normally closed contact.

Logic operation: This parameter can be used if required to permit the channel to be switched using a logic operation (AND or OR) of the switching object with an additionally inserted object "Logic operation, Channel x". The logic object is not governed by any time delay, i.e. the logic operation always takes immediate effect.

Note: An AND function may be used for lock / release of switching a channel.

ON delay: This parameter can be used to set an ON delay in the range of 0.5 seconds to 90 minutes. It has no effect on the logic objects.

OFF delay: This parameter can be used to set an OFF delay in the range of 0.5 seconds to 90 minutes. It has no effect on the logic objects.

Initial value of switch and logic object at mains voltage recovery: This parameter is used, when a logic operation is activated, to specify the initial value of the switch and logic object upon recovery of the mains voltage. If no logic operation is activated, the parameter "Output state at mains voltage recovery" is shown instead.

ON time during night mode: This parameter is used to select for how long a channel can be switched on when the "Night mode" object is activated.

If another switching On command is received during an active on-period, then the timer will be reset to its initial value and the operating interval extended accordingly.

Blinking before OFF in night mode (respectively Blinking before OFF): This parameter is used to set whether, during night mode operation (respectively during time switch operation), a channel is to signal by multiple switching off and on again of the lighting prior to expiration of the on-period that the channel will be permanently switched off about 30 s after it was temporarily switched off for the first time.

Parameter window "8-bit Scenes"

With 8-bit scene control the saving and recalling of a scene is triggered by a telegram with an 8-bit object. The most significant bit 7 specifies whether the scene is to be saved or recalled. Bit 6 has no meaning at present and must be set to "0". Bit 0 to bit 5 contain (in binary coded

25 A16 binary, blinking before off 981C01

form) the number of the desired scene as a decimal number in the range from 1 to 64 (where scene number 1 is the binary number 0, scene number 2 is the binary number 1, etc.).

Each actuator channel can be integrated in up to 8 scenes.

Scene assignments for channel: This parameter is used to set for which channel the scene assignments are to be shown so that new ones can be assigned and existing ones altered.

Channel A: Assignment 1 with Scene [1...64] (0=disabled): This parameter can be used to link channel A to a scene number in the range from 1 to 64. "0" means "no scene assigned" (scene control disabled).

Note: If a scene is called before a switching state was saved for it, the corresponding channel will be switched off.

The assignments 2 to 8 for channel A and the assignments for the other channels are made in similar manner to assignment 1 for channel A.

Block diagram of a channel

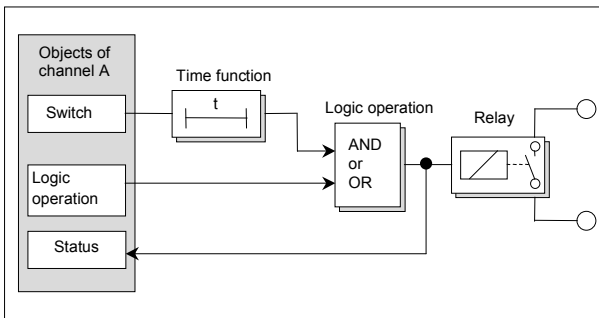

Communication objects

Maximum number of group addresses: 106
 Maximum number of associations: 106

Note

The view of the objects can be arranged individually i.e. this view can vary.

The following 17 communication objects are shown for the 16 channels switching actuator N 567/22 in the as-delivered state.

Number	Name	Object Function	Length	C	R	W	T	U
0	Status direct mode	On / Off	1 bit	C	R	-	T	-
3	Switch, Channel A	On / Off	1 bit	C	R	W	T	-
7	Switch, Channel B	On / Off	1 bit	C	R	W	T	-
11	Switch, Channel C	On / Off	1 bit	C	R	W	T	-
15	Switch, Channel D	On / Off	1 bit	C	R	W	T	-
19	Switch, Channel E	On / Off	1 bit	C	R	W	T	-
23	Switch, Channel F	On / Off	1 bit	C	R	W	T	-
27	Switch, Channel G	On / Off	1 bit	C	R	W	T	-
31	Switch, Channel H	On / Off	1 bit	C	R	W	T	-
35	Switch, Channel a	On / Off	1 bit	C	R	W	T	-
39	Switch, Channel b	On / Off	1 bit	C	R	W	T	-
43	Switch, Channel c	On / Off	1 bit	C	R	W	T	-
47	Switch, Channel d	On / Off	1 bit	C	R	W	T	-
51	Switch, Channel e	On / Off	1 bit	C	R	W	T	-
55	Switch, Channel f	On / Off	1 bit	C	R	W	T	-
59	Switch, Channel g	On / Off	1 bit	C	R	W	T	-
63	Switch, Channel h	On / Off	1 bit	C	R	W	T	-

The following 66 communication objects are shown for the 8-fold switching actuator N 567/22 when all additional functions were activated.

Number	Name	Object Function	Length	C	R	W	T	U
0	Status direct mode	On / Off	1 bit	C	R	-	T	-
1	8 bit scene	recall / program	1 Byte	C	R	W	T	-
2	Night mode, Channel A	On / Off	1 bit	C	R	W	T	-
3	Switch, Channel A	On / Off	1 bit	C	R	W	T	-
4	Logic operation, Channel A	On / Off	1 bit	C	R	W	T	-
5	Status switch, Channel A	On / Off	1 bit	C	R	-	T	-
6	Night mode, Channel B	On / Off	1 bit	C	R	W	T	-
7	Switch, Channel B	On / Off	1 bit	C	R	W	T	-
8	Logic operation, Channel B	On / Off	1 bit	C	R	W	T	-
9	Status switch, Channel B	On / Off	1 bit	C	R	-	T	-
10	Night mode, Channel C	On / Off	1 bit	C	R	W	T	-
11	Switch, Channel C	On / Off	1 bit	C	R	W	T	-
12	Logic operation, Channel C	On / Off	1 bit	C	R	W	T	-
13	Status switch, Channel C	On / Off	1 bit	C	R	-	T	-
14	Night mode, channel D	On / Off	1 bit	C	R	W	T	-
15	Switch, Channel D	On / Off	1 bit	C	R	W	T	-
16	Logic operation, Channel D	On / Off	1 bit	C	R	W	T	-
17	Status switch, Channel D	On / Off	1 bit	C	R	-	T	-
18	Night mode, channel E	On / Off	1 bit	C	R	W	T	-
19	Switch, Channel E	On / Off	1 bit	C	R	W	T	-
20	Logic operation, Channel E	On / Off	1 bit	C	R	W	T	-
21	Status switch, Channel E	On / Off	1 bit	C	R	-	T	-
22	Night mode, channel F	On / Off	1 bit	C	R	W	T	-
23	Switch, Channel F	On / Off	1 bit	C	R	W	T	-
24	Logic operation, Channel F	On / Off	1 bit	C	R	W	T	-
25	Status switch, Channel F	On / Off	1 bit	C	R	-	T	-
26	Night mode, channel G	On / Off	1 bit	C	R	W	T	-
27	Switch, Channel G	On / Off	1 bit	C	R	W	T	-
28	Logic operation, Channel G	On / Off	1 bit	C	R	W	T	-
29	Status switch, Channel G	On / Off	1 bit	C	R	-	T	-
30	Night mode, channel H	On / Off	1 bit	C	R	W	T	-
31	Switch, Channel H	On / Off	1 bit	C	R	W	T	-
32	Logic operation, Channel H	On / Off	1 bit	C	R	W	T	-
33	Status switch, Channel H	On / Off	1 bit	C	R	-	T	-
34	Night mode, Channel a	On / Off	1 bit	C	R	W	T	-
35	Switch, Channel a	On / Off	1 bit	C	R	W	T	-
36	Logic operation, Channel a	On / Off	1 bit	C	R	W	T	-
37	Status switch, Channel a	On / Off	1 bit	C	R	-	T	-
38	Night mode, Channel b	On / Off	1 bit	C	R	W	T	-
39	Switch, Channel b	On / Off	1 bit	C	R	W	T	-
40	Logic operation, Channel b	On / Off	1 bit	C	R	W	T	-
41	Status switch, Channel b	On / Off	1 bit	C	R	-	T	-
42	Night mode, Channel c	On / Off	1 bit	C	R	W	T	-
43	Switch, Channel c	On / Off	1 bit	C	R	W	T	-

25 A16 binary, blinking before off 981C01

□44	Logic operation, Channel c	On / Off	1 bit	C R W T -
□45	Status switch, Channel c	On / Off	1 bit	C R - T -
□46	Night mode, Channel d	On / Off	1 bit	C R W T -
□47	Switch, Channel d	On / Off	1 bit	C R W T -
□48	Logic operation, Channel d	On / Off	1 bit	C R W T -
□49	Status switch, Channel d	On / Off	1 bit	C R - T -
□50	Night mode, Channel e	On / Off	1 bit	C R W T -
□51	Switch, Channel e	On / Off	1 bit	C R W T -
□52	Logic operation, Channel e	On / Off	1 bit	C R W T -
□53	Status switch, Channel e	On / Off	1 bit	C R - T -
□54	Night mode, Channel f	On / Off	1 bit	C R W T -
□55	Switch, Channel f	On / Off	1 bit	C R W T -
□56	Logic operation, Channel f	On / Off	1 bit	C R W T -
□57	Status switch, Channel f	On / Off	1 bit	C R - T -
□58	Night mode, Channel g	On / Off	1 bit	C R W T -
□59	Switch, Channel g	On / Off	1 bit	C R W T -
□60	Logic operation, Channel g	On / Off	1 bit	C R W T -
□61	Status switch, Channel g	On / Off	1 bit	C R - T -
□62	Night mode, Channel h	On / Off	1 bit	C R W T -
□63	Switch, Channel h	On / Off	1 bit	C R W T -
□64	Logic operation, Channel h	On / Off	1 bit	C R W T -
□65	Status switch, Channel h	On / Off	1 bit	C R - T -

Obj	Object name	Function	Type	Flags
0	Status direct mode	On / Off	1 bit	CRT
<p>This object is used to signal that the actuator was switched to direct mode (direct mode = On) by the "direct mode" pushbutton on its upper side or that it was switched back from direct mode to bus mode (direct mode = Off).</p> <p>If direct mode is activated (the corresponding yellow LED on the upper side of the actuator shines), then direct switching of the actuator channels by means of a toggling function using the corresponding pushbuttons on the upper side of the actuator is enabled. The actuator does not perform the switching of scene commands received via the bus but stores them as the desired state.</p> <p>After returning to bus mode (the yellow LED for indicating direct mode on the upper side of the actuator is switched off) the actuator compares the actual states of the channels with the stored states and automatically eliminates any deviations of the actual states from the stored desired states.</p> <p>The direct mode status is automatically transmitted after a mains voltage recovery.</p>				
1	8 bit scene	recall / program	1 byte	CRWT
<p>This object is used to recall the 8 bit scene with the number x or to program it. Bits 0...5 hold the scene number. If bit 7 = log. 1, then the scene is programmed; if bit 7 = log. 0, then the scene is recalled. Bit 6 has no meaning at present and must be set to logical 0.</p>				

Obj	Object name	Function	Type	Flags
2	Night mode, Channel A	On / Off	1 bit	CRWT
<p>This object can be used to activate or deactivate "Night mode" for channel A via the bus. The object can be sent, for example, from a pushbutton, a time switch or a building automation system. If a logic 1 is received, then the channel will switch over to night mode.</p> <p>In "Night mode", a channel can no longer be switched on permanently but only for a limited period (cleaning light for e.g. 30 minutes). If the parameter "Blinking before Off" is set to "Yes" (see the parameter page "Channel X"), then multiple switching off and on again of the lighting prior to expiration of the parameterized on-period during night or time switch operation will signal that the channel will be permanently switched off about 30 s after it is temporarily switched off for the first time. The end of the operating interval can thus be recognized and the lighting switched on again, e.g. for another 30 minutes, by repressing the light switch.</p> <p>If the object "Night mode" is not used for a channel, then the channel can be permanently switched on at any time.</p>				
3	Switch, Channel A	On / Off	1 bit	CRWT
<p>This object is used to receive the switching telegrams that are transferred to the relay channel via the timer function where applicable. If a logic operation is parameterized, then the result of the timer function forms the 1st value of the logic operation for the channel.</p>				
4	Logic operation, Channel A	On / Off	1 bit	CRWT
<p>This object is used to receive the switching data for the 2nd input of the logic operation of the channel in question. With the parameter setting "no logic operation", this object has no function and is not shown.</p>				
5	Status switch, Channel A	On / Off	1 bit	CRT
<p>The current switching state of the channel is saved in the status object and can be queried with a read request or, after suitable parameterization, be automatically sent each time the object value changes.</p>				

The explanations above apply to the communication objects of all other channels accordingly.

25 A16 binary, blinking before off 981C01

Parameters

Parameter window "Functions, Objects"

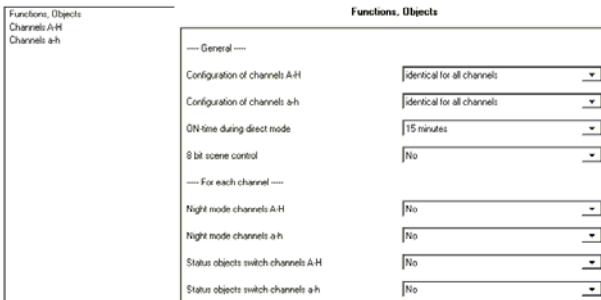

If individual configuration per channel is desired and parameters for more functions and objects set to "Yes", then an additional parameter will be shown on this parameter page and more parameter windows added (see the following graphic).

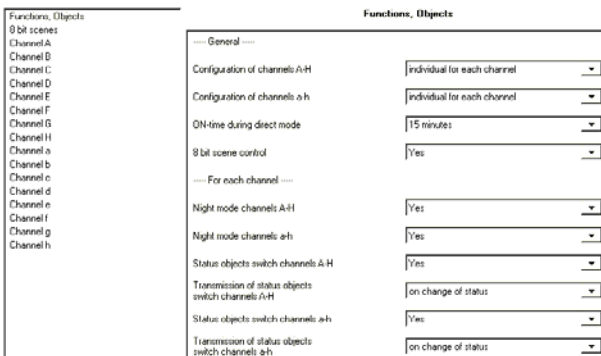

Parameters	Settings
Configuration of channels A-H	individual for each channel identical for all channels
This parameter is used to set whether only one parameter window for joint and identical configuration of the switching channels A...H appears or one parameter window per channel for individual configuration of each switching channel is shown.	
Configuration of channels a-h	individual for each channel identical for all channels
This parameter is used to set whether only one parameter window for joint and identical configuration of the switching channels a...h appears or one parameter window per channel for individual configuration of each switching channel is shown.	

Parameters	Settings
ON-time during direct mode	5 minutes, 10 minutes, 15 minutes , 20 minutes, 30 minutes, 45 minutes, 60 minutes, unlimited
This parameter is used to set whether direct mode is to be permanently switched on using the pushbutton for operating mode selection and has to be switched off again by repressing the pushbutton ("unlimited"), or whether it is switched on for a limited period and automatically switched off again after expiration of the set on-period. The time-limited switching on of the direct mode ensures that the bus mode cannot be permanently blocked by the direct mode. Each time the pushbutton for switching the channels in direct mode is actuated, direct mode is prolonged by the configured on-period.	
8-bit scene control	No Yes
This parameter is used to set whether the actuator is to be integrated in an 8-bit scene control. If it is, the corresponding communication object and the parameter page "Scenes" for allocating up to 8 scene numbers per switching channel will appear.	
Night mode channels A-H	No Yes
This parameter is used to set whether an additional "Night mode" communication object is to be made available per switching channel. If it is, the parameter "on-period in night mode" will be added in the parameter windows for channels A-H for setting the desired operating interval.	
Night mode channels a-h	No Yes
This parameter is used to set whether an additional "Night mode" communication object is to be made available per switching channel. If it is, the parameter "on-period in night mode" will be added in the parameter windows for channels a-h for setting the desired operating interval.	
Status objects switch channels A-H	No Yes
This parameter is used to set whether a communication object "Status object switch" is to be made available per channel. The status objects can be used, for example, to indicate the current switching state of the channels on a display or a PC. If status objects are desired, then the following parameter "Transmission of status objects channels A-H" appears.	
Transmission of status objects switch channels A-H	using read request only on change of status
Depending on the configuration, the status objects are automatically sent each time the status changes or only when there is a read request.	

25 A16 binary, blinking before off 981C01

Parameters	Settings
Status objects switch channels a-h	No Yes
This parameter is used to set whether a communication object "Status object switch" is to be made available per channel. The status objects can be used, for example, to indicate the current switching state of the channels on a display or a PC. If status objects are desired, then the following parameter "Transmission of status objects channels a-h" appears.	
Transmission of status objects switch channels a-h	using read request only on change of status
Depending on the configuration, the status objects are automatically sent each time the status changes or only when there is a read request.	

Parameter window "Channels A-H" or "Channel X" (Parameter window "Channels a-h" or "Channel x")

Depending on the setting of the parameter "Configuration channels A-H" (respectively of the parameter "Configuration channels a-h"), a parameter window for the joint and identical parameterization of all channels or one window per channel for individual configuration of each channel is shown.

Channel A

Operating mode	Normal mode
Relay mode	normally open contact
Logic operation	no logic operation
ON-delay	disabled
OFF-delay	disabled
Output state at mains voltage recovery	as before voltage failure
ON-time during night mode	30 minutes
Blinking before OFF in night mode	Yes

Parameters	Settings
Operating mode	Normal mode Time switch
This parameter is used to set whether the channel is to work as a "normal switch" that can be governed by a switching On and/or Off delay and a logic operation, or whether it is to work as a pure time switch that is switched on only via an ON command and automatically switched off again upon expiration of the configured on-period.	

Parameters	Settings
Relay mode	normally open contact normally closed contact
This parameter defines the behavior of the relay contact. If the setting "normally closed contact" is selected, switching off always closes the contact and switching on always opens the contact. "normally open contact": Off telegram = contact open, On telegram = contact closed. "normally closed contact": Off telegram = contact closed, On telegram = contact open.	
Logic operation	no logic operation AND function OR function
This parameter can be used if required to switch the channel by means of a logic operation of the switching object with an additionally inserted "Logic object, channel x". The logic operation object is not subject to any time delay, i.e. the logic operation always takes immediate effect.	
ON-delay	disabled, 0.5 s, 1 s, 2 s, 3 s, 4 s, 5 s, 8 s, 10 s, 12 s, 15 s, 20 s, 25 s, 30 s, 45 s, 60 s, 1.5 min., 2 min., 3 min., 5 min., 8 min., 10 min., 15 min., 20 min., 30 min., 45 min., 60 min., 90 minutes
This parameter is used to set the desired ON delay. The pre-setting "disabled" means that switching-on commands are performed immediately. A set ON delay is effective only on the object "Switch channel x" and not on any corresponding logic object that may exist.	
OFF-delay	disabled, 0.5 s, 1 s, 2 s, 3 s, 4 s, 5 s, 8 s, 10 s, 12 s, 15 s, 20 s, 25 s, 30 s, 45 s, 60 s, 1.5 min., 2 min., 3 min., 5 min., 8 min., 10 min., 15 min., 20 min., 30 min., 45 min., 60 min., 90 minutes
This parameter is used to set the desired OFF delay. The pre-setting "disabled" means that switching off commands are performed immediately. A set OFF delay is effective only on the object "Switch channel x" and not on any corresponding logic object that may exist.	
Output state at mains voltage recovery	Off On as before voltage failure
If there is a mains voltage failure, all actuator channels will be forced to switch off after their current switching state was saved. The actuator electronics is powered by the mains, i.e. the actuator cannot switch if there is no mains voltage. This parameter is used to set the desired switching state of the channel after mains voltage recovery when no logic operation is activated.	

25 A16 binary, blinking before off 981C01

Parameters	Settings
Initial value of switch and logic object at mains voltage recovery	as before voltage failure / as before voltage failure, as before voltage failure / Off, as before voltage failure / On, Off / as before voltage failure, Off / Off, Off / On, On / as before voltage failure, On / Off, On / On
The parameter for setting the initial value for the switch and logic object after mains voltage recovery appears instead of the parameter "switching state at mains voltage recovery" when a logic operation is activated.	
ON-time during night mode	1.5; 2; 3; 5; 8; 10; 15; 20; 30 ; 45; 60; 90 minutes
This parameter is used to select for how long a channel can be switched on when the "Night mode" object is activated. If another switching on command is received during an active on-period, then the timer will be reset to its initial value and the operating interval extended accordingly.	
Blinking before OFF in night mode	No Yes
This parameter can be used to activate a warning before OFF. About 30 s before expiration of the set on-period, the switching channel is switched off for the first time for about 1 s and then back on again for about 10 s. This is repeated another two times before the output is then permanently switched off. If the channel is used for lighting control, a user is thus given advance warning and can switch the lighting back on again.	

Time switch mode

If the parameter "Operating mode" is set to "Time switch", then the parameters described before will appear.

Channel A

Operating mode	Time switch
Relay mode	normally open contact
Logic operation	AND function
ON-time	5 minutes
Initial value of logic object at mains voltage recovery	as before voltage failure
Blinking before OFF	Yes

Parameters	Settings
Operating mode	Normal mode Time switch
This parameter is used to set whether the channel is to work as a pure time switch that is switched on only via an ON command and automatically switched off again upon expiration of the configured on-period or whether it is to work as a "normal switch" that can be governed by a switching On and/or Off delay if applicable.	
Relay mode	normally open contact normally closed contact
This parameter defines the behavior of the relay contact. If the setting "normally closed contact" is selected, switching off always closes the contact and switching on always opens the contact. "normally open contact": Off telegram = contact open, On telegram = contact closed. "normally closed contact": Off telegram = contact closed, On telegram = contact open.	
Logic operation	no logic operation AND function OR function
This parameter can be used if required to switch the channel by means of a logic operation of the switching object with an additionally inserted logic object. The logic operation object is not subject to any time delay, i.e. the logic operation always takes immediate effect. <u>Note:</u> An AND function may be used for lock / release of switching a channel.	
ON-time	disabled, 0.5 s, 1 s, 2 s, 3 s, 4 s, 5 s, 8 s, 10 s, 12 s, 15 s, 20 s, 25 s, 30 s, 45 s, 60 s, 1.5 min., 2 min., 3 min., 5 min. , 8 min., 10 min., 15 min., 20 min., 30 min., 45 min., 60 min., 90 minutes
This parameter is used to set the desired on-period when "Time switch" operation was selected as operating mode. If another switching ON command is received during an active on-period, then the timer will be reset to its initial value and the operating interval extended accordingly. A "Blinking before OFF" should not be activated until after an on-period \geq of at least 1 minute.	
Initial value of logic object at mains voltage recovery	Off On As before voltage failure
This parameter is used to set the start value of the logic object at mains voltage recovery. This parameter is shown in addition when an AND or an OR operation is desired during time switch operation.	

25 A16 binary, blinking before off 981C01

Parameters	Settings
Blinking before OFF	No Yes
<p>This parameter can be used to activate a warning before OFF. About 30 s before expiration of the set on-period, the switching channel is switched off for the first time for about 1 s and then back on again for about 10 s. This is repeated another two times before the output is then permanently switched off. If the channel is used for lighting control, a user is thus given advance warning and can switch the lighting back on again.</p>	

Parameter window "8-bit scenes"

8 bit scenes

Scene assignments for channel	A
Channel A: Assignment 1 with scene [1...64] (0=disable)	0
Channel A: Assignment 2	0
Channel A: Assignment 3	0
Channel A: Assignment 4	0
Channel A: Assignment 5	0
Channel A: Assignment 6	0
Channel A: Assignment 7	0
Channel A: Assignment 8	0

Parameters	Settings
Scene assignments for channel	A B C . . . h
<p>This parameter is used to set for which channel the scene assignments are to be shown so that they can be assigned or altered.</p>	
Channel A: Assignment 1 with scene [1...64] (0=disabled)	0-64, 0
<p>This parameter can be used to link channel A to a scene number in the range from 1 to 64. 0 means "No scene assigned" (link unused). <u>Note:</u> If a scene is recalled before a switching state was programmed for it, the channel in question will be switched off.</p>	
Channel A: Assignment 2	0-64, 0
<p>This parameter can be used to link channel A to another scene number in the range from 1 to 64. 0 means "No scene assigned" (link unused). <u>Note:</u> If a scene is recalled before a switching state was programmed for it, the channel in question will be switched off.</p>	

and so on until

Channel A: Assignment 8	0-64, 0
<p>This parameter can be used to link channel A to another scene number in the range from 1 to 64. 0 means "No scene assigned" (link unused). <u>Note:</u> If a scene is recalled before a switching state was programmed for it, the channel in question will be switched off.</p>	

25 A16 binary, blinking before off 981C01

Timing diagrams: examples of one channel

1. Switching without a time delay, no logic operation

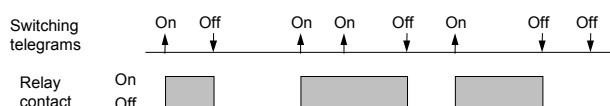

2. Switching with an On delay, no logic operation

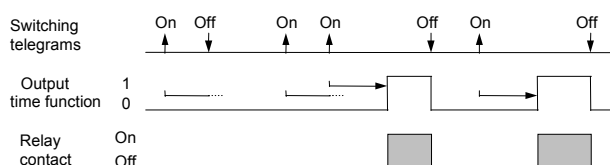

3. Switching with an Off delay, no logic operation

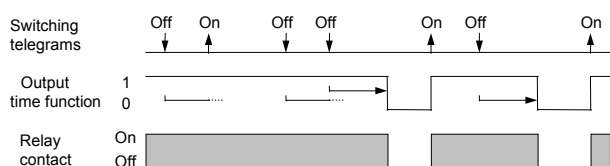

4. Switching with an On and Off delay, no logic operation

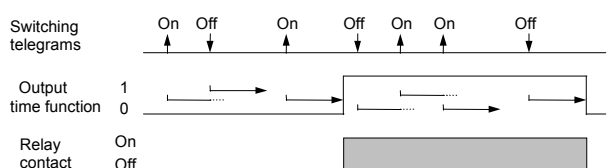

5. Switching with time switch function, no logic operation

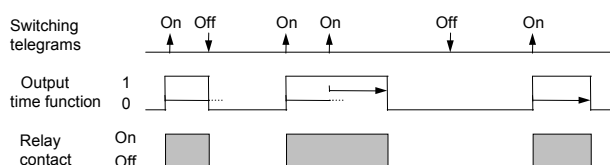

6. Switching with AND function, no time delays

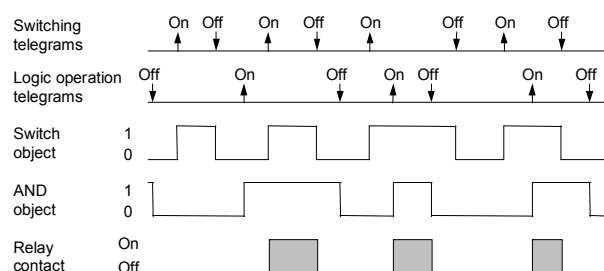

7. Switching with OR function, with an On delay

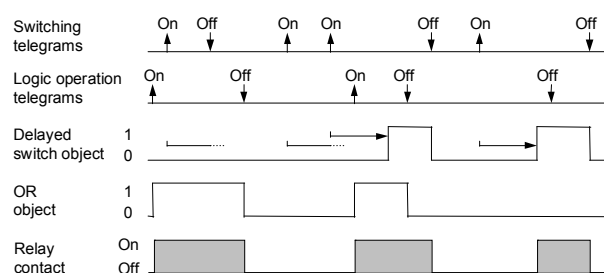

8. Switching with AND function, with On and Off delay

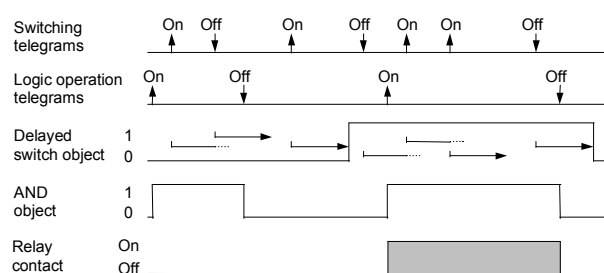

9. Switching with OR function and time switch function

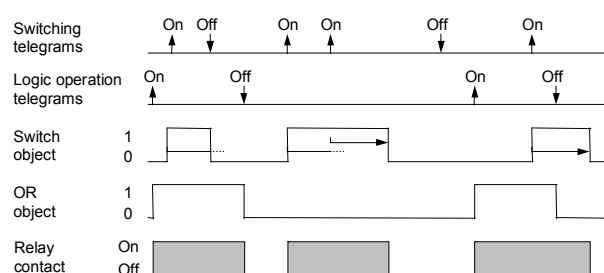

GAMMA *instabus*

Application program description

April 2009

25 A16 binary, blinking before off 981C01

Space for notes